



KIP 79 Series

User Manual

Version A.0



Thank you for purchasing the KIP 7970 Series.

This Hardware Operation Guide contains functional and operational explanations for the KIP 7970 Series.

Please read this Hardware Operation Guide carefully before using the Printer.

Please keep this Hardware Operation Guide for future reference.

1. When this product is installed in North America.

This product complies with part 15 of the FCC Rules. Operation is subject to the following two conditions: (1) This product may not cause harmful interference, and (2) this device must accept any interference received, including interference that may cause undesired operation.

FCC CAUTION

Changes or modifications not expressly approved by the party responsible for compliance could void the user's authority to operate the product.

Note: This product has been tested and found to comply with the limits for a Class A digital equipment, pursuant to part 15 of the FCC Rules. These limits are designed to provide reasonable protection against harmful interference when the product is operated in a commercial environment. This product generates, uses, and can radiate radio frequency energy and, if not installed and used in accordance with the instruction manual,, may cause harmful interference to radio communications. Operation of this product in a residential area is likely to cause harmful interference in which case the user will be required to correct the interference at his own expense.

This product complies with Part 15 of FCC Rules and Industry Canada licence-exempt RSS standard(s). Operation is subject to the following two conditions: (1) this product may not cause interference, and (2) this product must accept any interference, including interference that may cause undesired operation of this product.

Le présent appareil est conforme aux la partie 15 des règles de la FCC et CNR d'Industrie Canada applicables aux appareils radio exempts de licence. L'exploitation est autorisée aux deux conditions suivantes : (1) l'appareil ne doit pas produire de brouillage, et (2) l'utilisateur de l'appareil doit accepter tout brouillage radioélectrique subi, même si le brouillage est susceptible d'en compromettre le fonctionnement.

Contains FCC ID: VP8-13551

Contains IC: 7391A-13551

2. When this product is installed in Europe

This product complies with the requirements in Pub.22 of CISPR Rules for a Class A computing equipment.

Operation of this product in a residential area may cause unacceptable interference to radio and TV reception requiring the operator to take whatever steps are necessary to correct the interference.

Do not install product around other electronic equipment or other precision instruments. Other equipment may be effected by electrical noise during operation.

If the product is installed near other electronic equipment, such as a TV or a radio, interference to said equipment, such as noise or flickering, may occur.

Use a separate power line and install the PRINTER as far as possible from said equipment.

KIP 7970 Series is an ENERGY STAR qualified Wide Format Printer / MFP equipment.



The International ENERGY STAR® Office Equipment Program is an international program that promotes energy saving through the penetration of energy efficient computers and other office equipment. The program backs the development and dissemination of products with functions that effectively reduce energy consumption. It is an open system in which business proprietors can participate voluntarily. The targeted products are office equipment such as computers, monitors, printers, facsimiles, copiers, scanners, and multifunction devices. Their standards and logos are uniform among participating nations.

The symbol shown indicates that this product conforms to Directive 2012/19/EC of the European Parliament and the council of 4 July 2012 on waste electrical and electronic equipment (WEEE) and does not apply to countries outside of EU.



Only For EU Member States

Das Gerät ist nicht für die Benutzung am Bildschirmarbeitsplatz gemäß BildscharbV vorgesehen.

The symbol shown indicates that this product conforms to SJ/T11364-2006 of People's Republic of China Electronic Industry Standard and does not apply to countries outside of People's Republic of China.



The symbol shown indicates that this product conforms to GB 18455-2001 SJ/T 11364-2006 of National Standard of the People's Republic of China and does not apply to countries outside of People's Republic of China.



The product shown with available options. May vary from the actual product.

Safety Warning

The following warnings are very important in order to safely use this product.
These notes are important in preventing danger to the operator or operation of the printer.

The following symbols are found throughout the USER'S Manual and have the following meaning:



WARNING

This WARNING mark means that there is a possibility of death or serious injury if you ignore or do not follow the said instruction.



CAUTION

This CAUTION mark means that there is a possibility of injury or physical damage if you ignore or do not follow the said instruction.

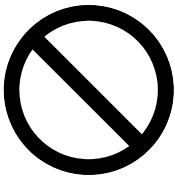

When marked with this symbol, "DO NOT ATTEMPT".



When marked with this symbol, "pay close attention to".



There are extremely hot parts inside.
Do not touch any parts, or you will be burnt.



WARNING

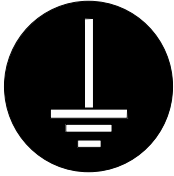

Ground the product with a correct ground source or you may be electrically shocked.



1. The Power source should be as follows:
220 to 240V plus 6% or minus 10%, 50/60Hz, 16A or higher
2. Use a circuit with a dedicated breaker.
3. Install the product as close to the wall outlet as possible.
4. If you wish to move the printer, please contact your service personnel.



1. Do not remove the screw and do not open the cover if not instructed to do so in this User's Manual. If you ignore this warning, you may be burnt or receive an electric shock due to a hot item or electrically charged part inside of the printer.
2. Do not disassemble or tamper with the printer.
It may result in a fire or an electrical shock.

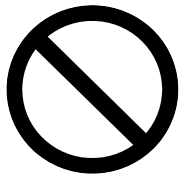

1. Do not plug in the printer into a multi-wire connector in which some other equipment is plugged into.
It may cause a fire due to outlet overheating.
2. Do not damage the Power Cord by stepping on or placing heavy items on it.
If the Power Cord is damaged, it may cause a fire or you may receive an electric shock. **REPLACE THE CORD IF DAMAGED!**

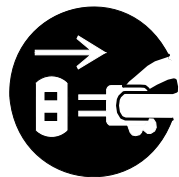

1. Do not put a flower vase, a flowerpot or any water-filled item on the product.
Spilt water could cause a fire or an electric shock.
2. If the product generates an abnormal smell or noise, turn it off and unplug it from the wall electrical outlet immediately.



Do not throw the toner into a fire or other sources of heat, as it can explode.



CAUTION

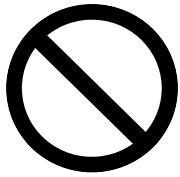

Do not install the printer in a humidified room or a dusty room. Also, do not install the printer on an unstable floor as injuries may occur.

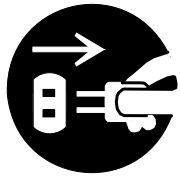

1. Unplug the printer before you move it.
The power cord may be damaged and it may result in a fire or electric shock.
2. If you do not use the printer for a long duration (holidays, company shutdown) turn off and unplug the printer from the outlet for safety.

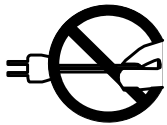

Do not pull the cord when you unplug the printer as you may damage the Power Cord.



There are hot items inside of the printer. Take great care not to touch these items when you remove mis-fed media.



Ventilate the room well if you print in a small area.

POWER CORD INSTRUCTION

The installation of (or exchange to) a power plug which fits in the wall outlet of the installation location shall be conducted in accordance with the following:



WARNING

Select a power plug which meets the following criteria;



- The plug has a voltage and current rating appropriate for the product's rating marked on its name plate.
- The plug meets regulatory requirements for the area.
- The plug is provided with a grounding pin or terminal.

If the appropriate plug does not fit the wall outlet in the installation, the customer shall install an appropriate outlet.

Connector Type:

Configuration	Standard	Rating	Usually found in
	IEC60320:C19	20A 250V (UL) 16A 250V (IEC)	

Plug Type: Model Rating 220-240V

Configuration	Standard	Rating	Usually found in
	NEMA6-20	20A 250V	North America (UL Listed)
	CEE7/7	16A 250V	European countries
	KS C 8305	16A 250V	Korea
	AS/NZS 3112	16A 250V	Australia New Zealand
	GB1002 GB2099.1	16A 250V	China
	IRAM 2073	16A 250V	Argentina

Cord Type

Standard	Rating	Usually found in
SJT 3X12AWG Long <4.5m	20A 250V	North America (UL Listed)
HO5VV-F 3X1.5mm ²	16A 250V	European countries Argentina
RVV 3X1.5mm ²	16A 250V	China

Chapter 1

Before Use

	Page
1.1 Installation Requirements	1- 2
1.2 Originals Prohibited from Duplication	1- 3
1.3 Features	1- 4
1.4 Specifications	1- 5
1.4.1 Printer Part	1- 5
1.4.2 Scanner Part (for MFP Model)	1- 7
1.5 Appearance	1- 8
1.5.1 Front	1- 8
1.5.2 Rear	1- 9
1.6 Specifications for Scan Original (for MFP Model)	1-10
1.6.1 Original Standards	1-10
1.6.2 Special Documents	1-10
1.6.3 "Do Not Scan" Originals	1-11
1.7 Specifications for Printing Media	1-14
1.7.1 Papers not available to use	1-14
1.7.2 Keeping the paper in the custody	1-15
1.7.3 Treatment against environmental condition	1-16

1.1 Installation Requirements

The following conditions are required for installation of the equipment.



1. Power source should be rated as follows.
220V - 240V plus 6% or minus 10%, 50/60Hz, 16A or higher
2. The equipment must be on an exclusive circuit.
3. The outlet must be near the equipment and easily accessible.

I Norge: Kan kobles til IT strøm distribusjonssystemer.



1. Make sure to connect this equipment to a grounded outlet.
2. For PLUGGABLE EQUIPMENT, the socket-outlet shall be installed near the equipment and shall be easily accessible.



1. The installation site must not have open flames, dust or ammonia gases.
2. The equipment must not be exposed to the air vents from air conditioners. It may affect the image quality.
3. The equipment should not be exposed to the direct sunlight. Please draw curtains to block any sunlight. When you open the Upper Unit to remove a mis-feed, do not expose the Photoconductive Drum to strong (intense) light as this will damage the Drum.



Ozone will be generated while this equipment is use, although the quantity generated is within safe levels. (See certifications.)
Ventilate the room, if required.

The site temperature range = 10 to 32 degrees Centigrade, with the humidity between 15% to 85% RH. (NON-CONDENSING)

Keep the printer away from water sources, boilers, humidifiers or refrigerators.

Keep ample room around the equipment to ensure comfortable operation.
(Refer to the following figure.)

The equipment must be leveled and the floor strength must be ample to sustain the weight of the equipment.

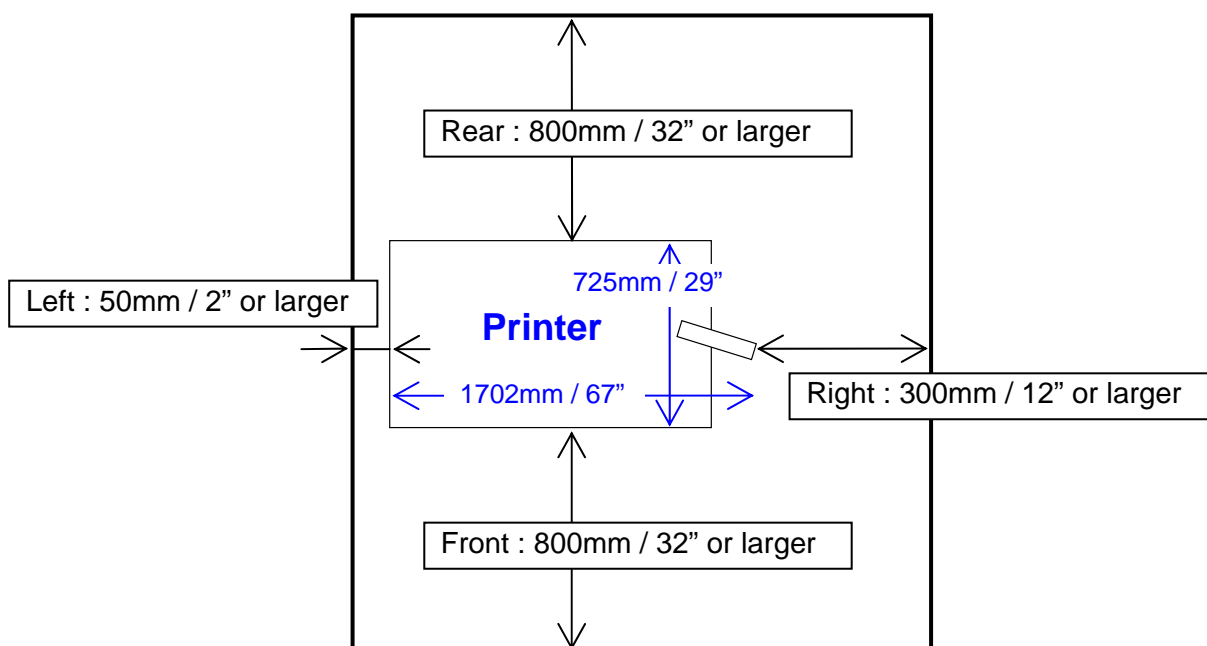

1.2 Originals Prohibited from Duplication

It is not necessarily allowed to copy every kind of original.

You may be punished by the law if only you possess the copy of some kind of original.

We recommend you to consider enough before you copy such original.

[Originals prohibited from copying by the law]

1. It is not allowed to copy Currency (Bill, Money, Bank Note, etc.), Government issued Negotiable Instruments (National Bonds, Security, Local Debt Bonds, etc.).
2. It is not allowed to copy Foreign Currency or Foreign Negotiable Instruments.
3. It is not allowed to copy unused postal stamps or government postcards without permission to make replica from Government.
4. It is not allowed to copy Government issued revenue stamps, certificate stamps which are prescribed by Liquor Tax Act or the Commodity Tax Act.

[Special items to be cared]

1. It is warned by the government to copy private issued securities (stock certificate, draft, check, goods ticket, etc.), commutation ticket or book of tickets, excluding that some specific company copies such originals as many as it requires for its own business.
2. We recommend you not to copy freely such originals as government issued passport, public or private issued licenses, automobile inspection certification, IDs and tickets like pass or meal.

Reference Law	Prohibited items to copy
Regulations to control fake currency and Bond.	Currency (Bill, Money, Bank Note, etc.), Government issued Negotiable Instruments (National Bonds, Security, Local Debt Bonds, etc.)
Control Law against Forged & faked Foreign Currency, Bill, Bank Note and Bond	Foreign Currency or Foreign Negotiable Instruments
Forged postal stamps control law	Unused postal stamps or government postcards
Forged revenue stamps control law	Government issued revenue stamps, and certificate stamps prescribed by Liquor Tax Act or Commodity Tax Act
Currency similarity securities Control Law	Private issued securities (stock, draft, check, goods ticket, etc.), commutation or book tickets

[Originals protected by the copyright]

It is prohibited to copy such originals as book, music, paintings, printed copy, maps, drawings, movie and pictures which are protected by the copyright, except for personnel or family use or similar purpose.

1.3 Features

- (1) KIP 79 Series is an Electro Photographic wide format LED printer/MFP. Advanced drivers and comprehensive print utilities make the KIP 79 Series an advanced, easy to use system. (some functions may be optional)
- (2) Selection from 4 models are available according to the requirement.
 - 4 rolls wide format MFP model
 - 4 rolls wide format printer model
 - 2 rolls wide format MFP model
 - 2 rolls wide format printer model
- (3) KIP HDP technology generates no waste toner.
- (4) The KIP HDP Plus imaging system produces high definition lines, distinctive greyscale and consistent blacks.
- (5) Density Compensation Process provides consistent image density in various environments.
- (6) KIP 79 Series Printer can make a print in a speed of 160mm per second.
- (7) The maximum paper width is 36" (914mm) wide, and the minimum is 11" (279mm). The maximum paper length is 6m (with 36" paper) or, and the minimum is 8.5" (210mm).
- (8) Flange type loading mechanism eases operator's media loading work.
- (9) Up to 600dpi print resolutions with an enhanced scanning system produces the highest quality images controlled by an advanced KIP Image Process System.
- (10) Easy access to USB port allows users to provide efficient productivity by using "File to Print" / "Scan to USB" (option).
- (11) 2-way print delivery suits the preference of the user's print handling. (rear stacking requires a stacking device, option)
- (12) Use of optional hardware finisher devices helps handling of the finished prints.
- (13) 12" multi-touch panel allows for tablet-like operation and image viewing.

Subject	Specification
Media	(Recommended Media) US model: Plain Paper Tracing Paper Film Europe/Asia model: Plain Paper Tracing Paper Film
Environmental condition for usage	Temperature: 10 to 32 degrees Centigrade Humidity: 15 to 85% RH
Interface	Ethernet (10 BASE-T, 100 BASE-TX, 1000 Base-T) Serial port (RS232-C) USB 2.0
Storage of consumables	(Media) Wrap the media surely to shut out the humidity. (Toner cartridge) Keep the toner cartridge away from the direct sunlight, and store it in the condition of 0 to 35 degrees Centigrade and 10 to 85% RH.

 NOTE

The above specifications are subject to change without notice.

1. 4. 2 Scanner Part (for MFP Model)

Subject	Specification
Scanning method	Contact Image Sensor (CIS) (5 pieces of A4 sized CIS)
Light source	LED (R/G/B)
Scanning speed (600 dpi, normal quality) (max)	Monochrome : 65mm/s Grayscale : 65mm/s Color : 22mm/s NOTE : The actual speed may vary by the scan software.
Setting of original	Face up
Starting point of scan	Center
Scan width	Max: 914.4mm / 36" Min : 210mm
Scan length	Max: 6,000mm / 19.7ft (Including the margin area) Min : 210mm / 8.5" (Including the margin area) NOTE : If the print is longer than 6,000mm, its image quality or the reliability of paper feeding is not guaranteed.
Optical resolution	600dpi
Digital resolution	200 / 300 / 400 / 600 dpi
Original transportation	Sheet through type
Transportable original thickness	Max: 1.60mm Min : 0.05mm NOTE : Suggest to change "It does not guarantee both scan/copy image quality and original feeding reliability in case the original is non-standard size one of which thickness is 0.25mm or thicker.

NOTE

The above specifications are subject to change without notice.

1.5 Appearance

1.5.1 Front



	Name of part	Function
1	User Interface (UI)	This is a Touch Screen, and many user operations are available. PLEASE DO NOT push the LCD area too strong.
2	Scanner Unit (MFP Model only)	Read the original with this unit when you make scan or copy.
3	Manual Table	Open here to insert a cut sheet or to pull the Upper Frame Unit.
4	Roll Decks	Each Roll Deck drawer holds 2 rolls of print media.
5	Power Switch	You can turn on/off.
6	Print Tray	These trays catch ejected prints.
7	Scan Abort Button (MFP Model only)	While scanning: emergency stop At Standby position: eject
8	Start Button (MFP Model only)	Starts scanning if the controlling software requires user intervention.
9	Original Guides (MFP Model only)	Feed the original under the Scanner Unit along the Original Guides.
10	Original Table (MFP Model only)	Put the original here and then feed it into the Scanner Unit when you make scan or copy.
11	USB Port (USB 2.0)	Your USB flash memory storage can be installed here. 5VDC max.

1.5.2 Rear



	Name of part	Function
1	Paper Exit Door	Open the Paper Exit Door when you remove the mis-fed media.
2	Dehumidify Heater Switch	Press "H" to turn on the Dehumidify Heater, and press "L" to turn it off.
3	Inlet Socket	Connect the power cord here.
4	Breaker	It is possible to shut off supplying the AC power.
5	USB Port (USB 2.0)	For an optional device Service Use. 5VDC max.
6	COM Port	Connect the cable from a finishing device (option). (D-Sub Connector 9 pins: max.12Vdc (Small))
7	LAN Port	Connect the LAN Cable to connect the KIP 7970 to the network. (Do not connect a telephone line.)

1. 6 Specifications for Scan Original (for MFP Model)

A scan original must satisfy the following specifications.

Thickness	0.05mm to 1.60mm
Width	210mm to 914.4mm
Length	210mm to 6,000mm

NOTE :

1. Suggest to change "It does not guarantee both scan/copy image quality and original feeding reliability in case the original is non-standard size one of which thickness is 0.25mm or thicker.
2. Image quality for an original over 6,000mm in length is not guaranteed.

1. 6. 1 Original Standards

- (1) The width of original must range from 8.5" to 36" (210mm to 914.4mm).
- (2) The length of original must range 8.5" (210mm) to 6,000mm
- (3) The thickness of original must range from 0.05mm to 0.25mm.
- (4) The shape of original must be square, and it must be standard sized.
- (5) The type of original must belong to any of the followings.
 - Plain paper
 - Coated paper (High or middle class plain paper is coated with the paint.)
 - Tracing paper
 - Pansy Trace Paper (Both sides of the film is sandwiched between Tracing paper.)
 - Film
 - Newspaper
 - Cardboard paper

1. 6. 2 Special Documents

The following kinds of originals are "special". It is possible to scan them, **but the image quality and feed reliability are not guaranteed.**

- (1) The type of original is acceptable, but the thickness and type may not be:
 - Booklets
 - Original with a Hanger
 - Cut and Pasted originals
- (2) These original may not damage the scanner, but these types are NOT recommended: following ones.
 - Cloth
 - Aluminium Kent Paper

1. 6. 3 “Do Not Scan” Originals

It is impossible to use the following types of originals because they are likely to damage the scanner.

Do not scan the following kinds of original, because you may damage the original or scanner itself!

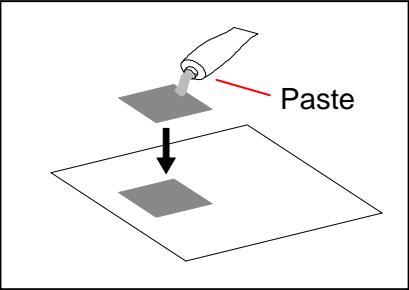
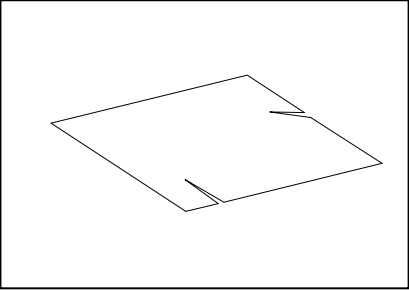
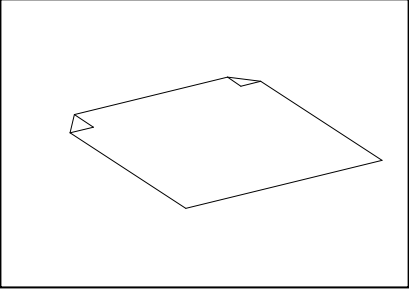
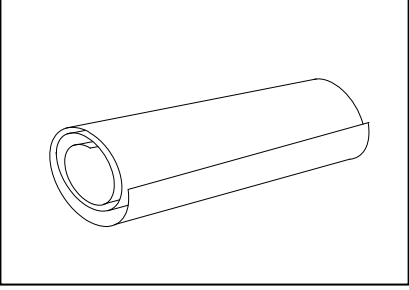
Sticked with paste	 <p>The diagram illustrates a brush applying a substance labeled 'Paste' to a small square on a larger sheet of paper. An arrow points from the brush to the square, and another arrow points from the word 'Paste' to the substance being applied.</p>
Torn	 <p>The diagram shows a rectangular piece of paper with jagged, irregular edges, representing a torn document.</p>
Folded (Leading edge)	 <p>The diagram shows a rectangular piece of paper folded in half, with the leading edge folded over.</p>
So much curled (Diameter is smaller than 80mm.)	 <p>The diagram shows a roll of paper, indicating it is curled.</p>

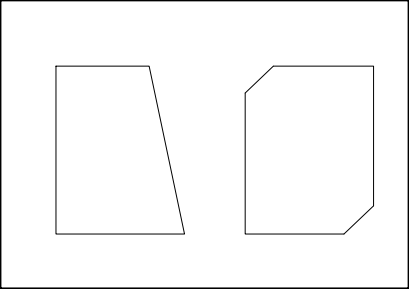
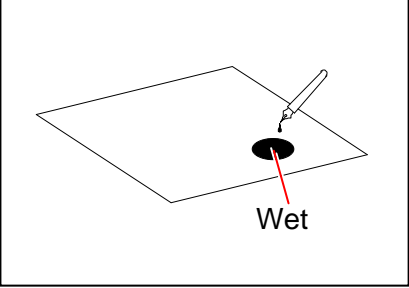
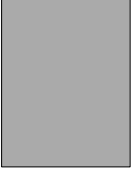
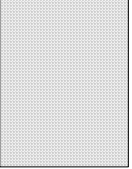
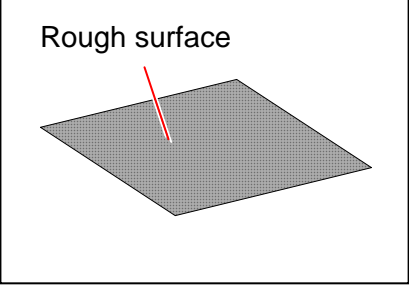
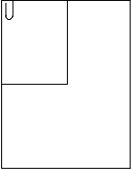
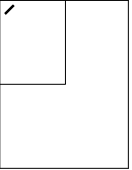
<p>Not square</p>	
<p>Wet image</p>	
<p>Made of metal or fabric</p>	<div style="display: flex; justify-content: space-around; align-items: center;"> <div style="text-align: center;"> <p>Metal</p>  </div> <div style="text-align: center;"> <p>Fabric</p>  </div> </div>
<p>Rough surface (Carbon paper for example)</p>	<p>Rough surface</p> 
<p>Clipped or stapled</p>	<div style="display: flex; justify-content: space-around; align-items: center;"> <div style="text-align: center;"> <p>Clipped</p>  </div> <div style="text-align: center;"> <p>Stapled</p>  </div> </div>

The following kinds of originals can be read with using a carrier sheet.

However, the image quality and feed reliability are not guaranteed.

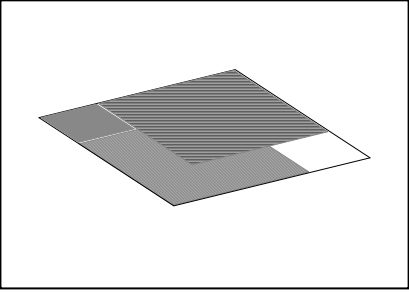
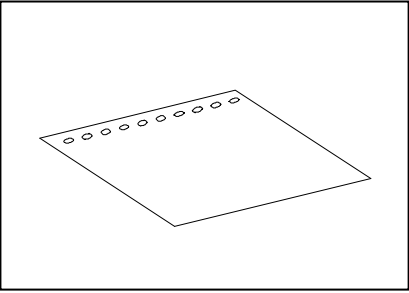
Patched	
Punched	

1.7 Specifications for the Printing Media

1.7.1 Papers not available to use

Do not use the following kinds of printing paper. Doing so may damage the print engine.

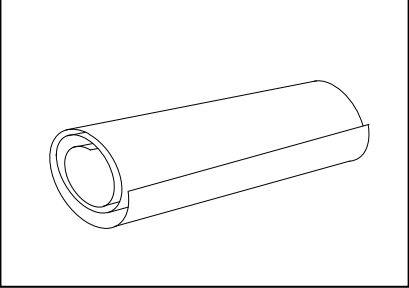
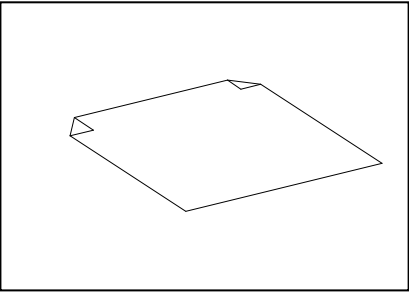
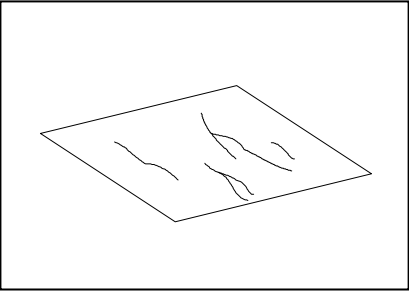
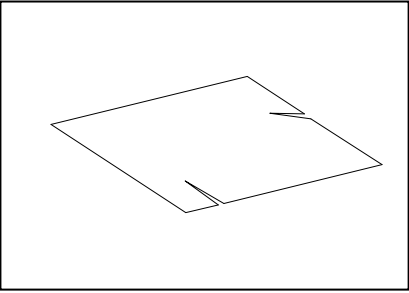
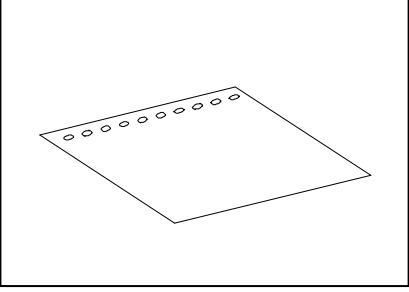
Excessively curled (a diameter of 50 mm or less)	
Folded	
Creased	
Torn	
Punched	

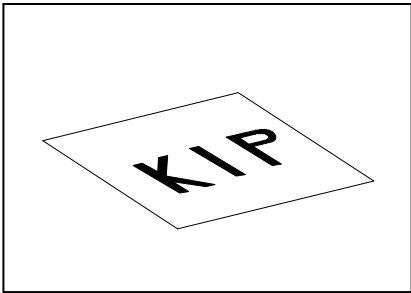
Pre-printed	
Extremely slippery	
Extremely sticky	
Extremely thin and soft	
OHP Film	

CAUTION

Do not use the paper with staple, or do not use such conductive paper as aluminium foil and carbon paper.

The above may result in a danger of fire.

NOTE

- (1) Print image may become light if printed on a rough surface of the paper.
- (2) Print image may become defective if the print paper has an excess curl.
- (3) It will become a cause for paper mis-feed, defective print image or paper creasing if you use a paper that does not satisfy the specification.
- (4) Do not use a paper of which surface is very special, such as thermal paper, art paper, aluminium foil, carbon paper and conductive paper.
- (5) Do not use papers with unpacked (exposed in high / low temperature & humidity) in a long period. Such papers may result in mis-feed, defective image or paper creasing.
- (6) Tracing paper exposed to air over a long period tends to cause a defective printing. Removing one round on the surface of the tracing roll paper from the beginning is recommended.
Refer to [2.3 Replacing Roll Media].

1. 7. 2 Keeping the paper in the custody

Keep the paper in the custody taking care of the following matters.

1. Do not expose the paper to the direct sunlight.
2. Keep the paper away from high humidity. (It must be less than 70%)
3. Put the paper on a flat place
4. If you will keep the paper in the custody, which you have already unpacked, put it into the polyethylene bag to avoid the humidity.

1.7.3 Treatment against environmental condition

Take a necessary treatment according to the environmental condition as shown below.

Humidity(%)	Possible problem	Necessary treatment
Low ↑	“Void of image”, “crease of paper” and other problems occurs when you print with plain paper and tracing paper.	1. Install the humidifier in the room, and humidify the room air. 2. Remove the paper from the machine right after the completion of print, and keep it in a polyethylene bag.
40%	“Void of image” occurs when you print with tracing paper.	If you will not make print soon, remove the tracing paper from the machine and keep it in a polyethylene bag.
70%		Remove the paper from the machine after everyday use, and keep it in a polyethylene bag.
↓ High	“Void of image” occurs when you print with plain paper and tracing paper.	If you will not make print soon, remove the tracing paper from the machine and keep it in a polyethylene bag.
	“Void of image”, “crease of paper” and other problems occurs when you print with plain paper and tracing paper.	1. Turn on the Dehumidify Heater. 2. Remove the paper from the machine right after the completion of print, and keep it in a polyethylene bag.

! NOTE

- (1) KIP 7970 Series is equipped with the Dehumidify Heater.
Using it in high humidity environment (65% or higher) is recommended.
Refer to [2.7 Dehumidifying Roll Media].
- (2) “Void of image” and “crease of paper” will occur in case of extremely high or low humidity.

Normal Print



If the media is humidified;

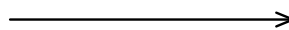

Crease of paper

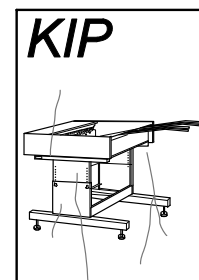

Normal Print



If the media is humidified;

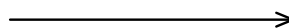

Loss of image



⚠ NOTE

- (3) Re-appearance of image (solid black image especially) may occur if you print with a humidified film.

When film is installed under the high humidity environment (higher than 60%RH), we also recommend that you turn on the Dehumidify Heater.

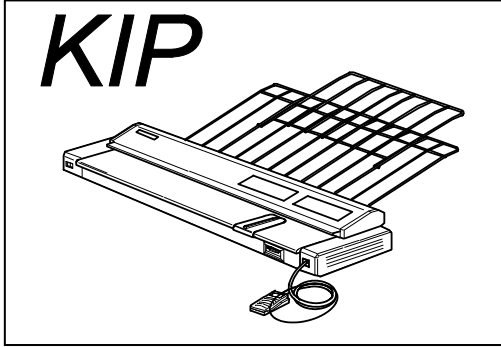

Normal print

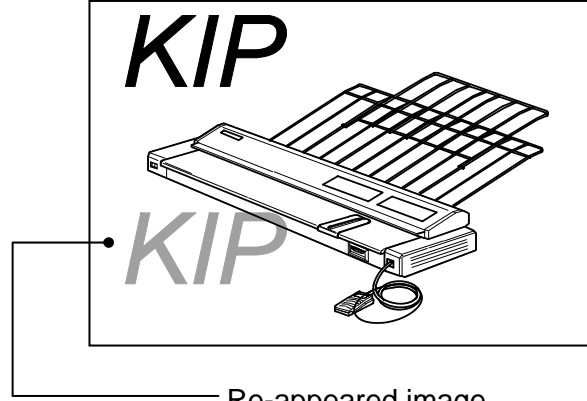

Re-appeared image

Chapter 2

Basic Operations

	Page
2.1 Turning on the Printer	2- 2
2.2 Turning off the Printer	2- 4
2.3 Replacing Roll Media	2- 5
2.4 Replacing Toner Cartridge	2-13
2.5 Placing Cut Sheet Media	2-17
2.6 Copying (for MFP Model)	2-18
2.7 Stop of Scan or Copy (for MFP Model)	2-21
2.8 Dehumidifying Roll Media	2-22

2.1 Turning on the Printer

1. Plug the power cord for Printer into a dedicated wall outlet.

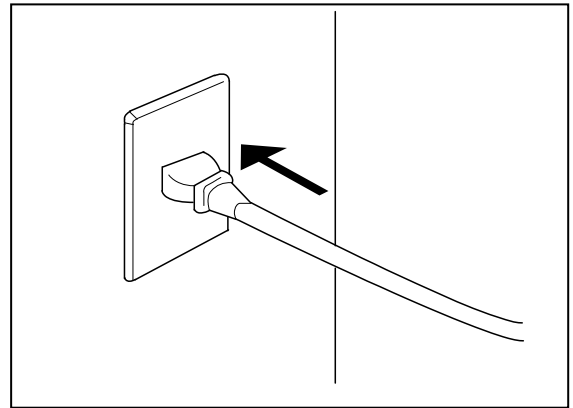

⚠ WARNING

- (1) Do not handle the Power Plug with wet hands, or you may receive an electrical shock.
- (2) Ground the printer for safety.
- (3) Do not plug the printer into a multi-wiring connector in which other devices are plugged into. It may overheat the outlet and may result in a fire.
- (4) The OUTLET must satisfy the following rated power condition.
220V to 240V plus 6% or minus 10%, 50/60Hz, 16A or higher

2. There is Power Switch on the right-front of the printer.
Press “|” side to turn on the printer.



Press this side.

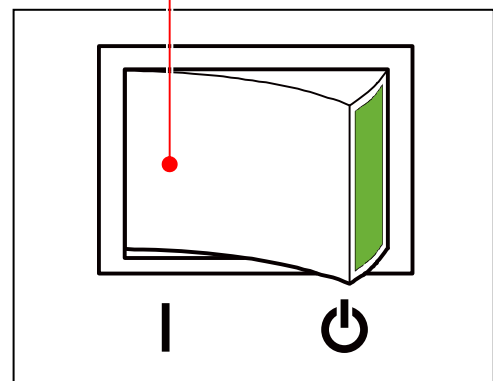

- The User Interface (UI) starts operating, and displays UI Screen in one minute. "Warming Up" is displayed in the status indication while warming up.

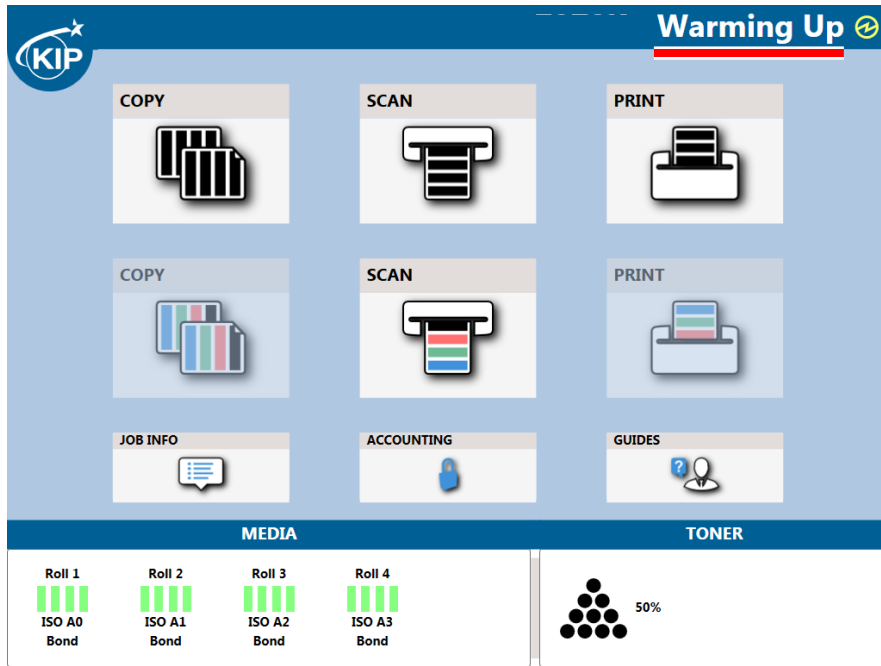

NOTE

It is not possible to print while displaying "Warming Up" in the status indication.

- "Ready" is displayed in the status indication when Printer is available to print.

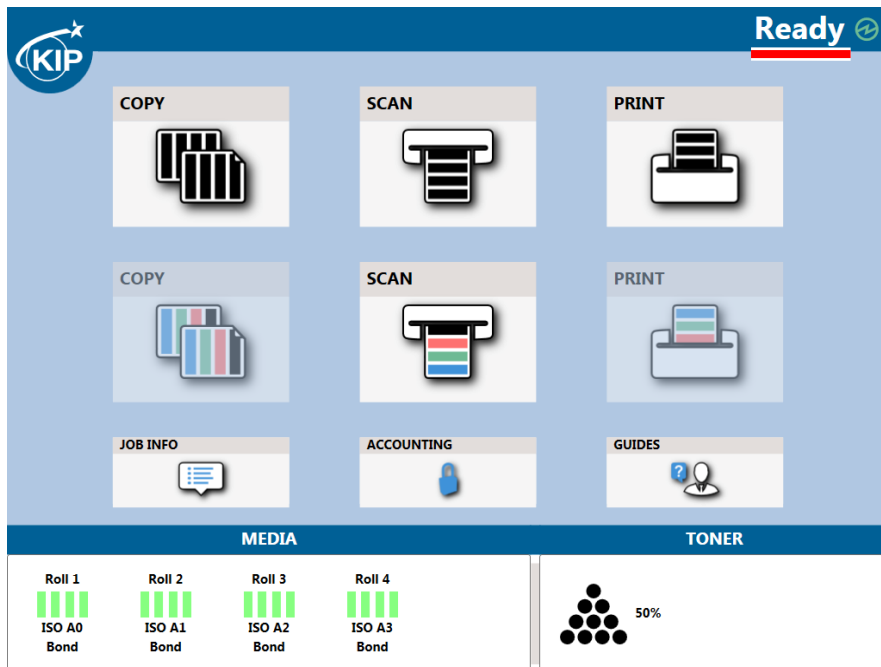

2.2 Turning off the Printer

1. Press “” side on the Power Switch to turn off the printer.



CAUTION

- (1) The Printer and the UI look to be shut down when you turn off the Printer. However, the embedded controller is still operating in approximately 1 minutes after Power Switch operation for the controller's shutdown.

Do not unplug the Printer before the controller's shutdown. Doing so may damage data or the device.

- (2) If you use Dehumidify Heater for Roll Decks, the printer should be plugged while the printer is OFF. Refer to [2.8 Dehumidifying Roll Media].

2.3 Replacing Roll Media

Reference

- (1) When the printer is running out of a roll media, the UI Screen will display “Roll Replacement” sign.

Follow the later procedure (or as noted in the UI’s User Guide) to load a roll media. Please refer to your Touch Screen Operator’s Guide for the UI screen.

- (2) It is recommended that a tracing paper / vellum roll is loaded to Roll Deck 3 or 4.

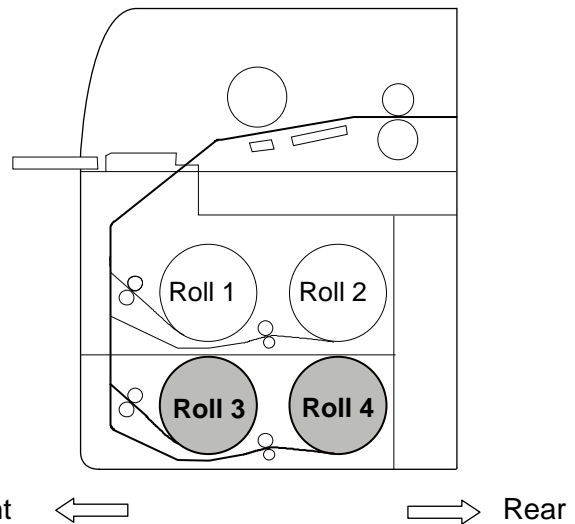

- (3) This section describes how to install a roll media to Roll Deck 1. The same procedure is applied to Roll Deck 2 / 3 / 4, unless otherwise noted.

1. Open Roll Deck (1).
Holding both Flanges (2), lift and remove a roll media or an empty roll core (3).

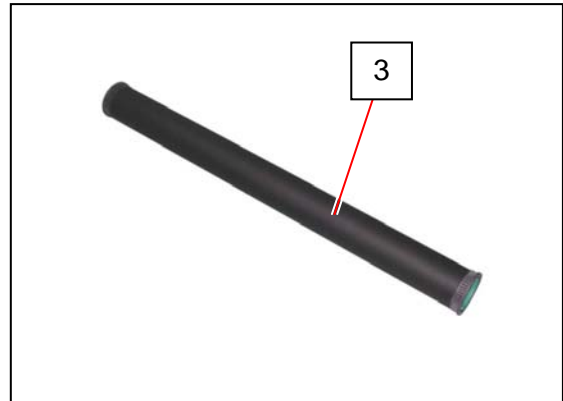
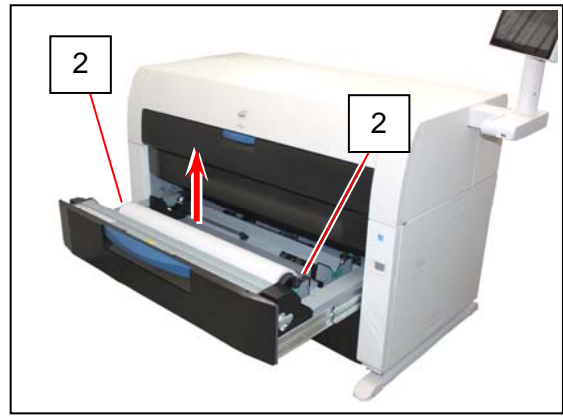
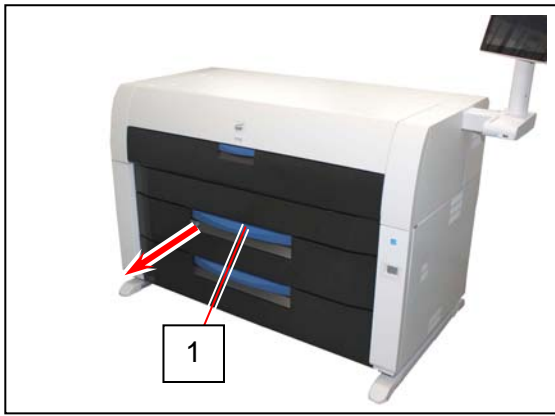

2. Raise the green lever (4) on Flange (2). Remove both Flanges (2) from the roll core (3).

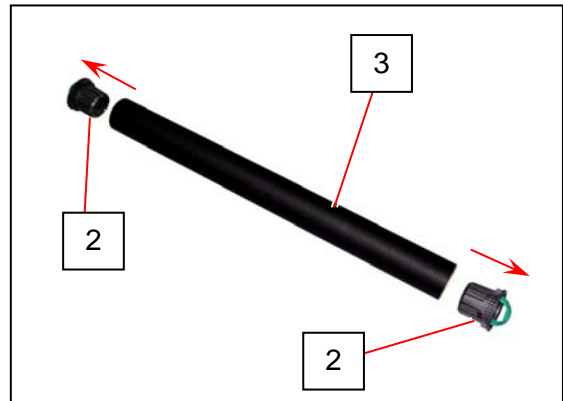
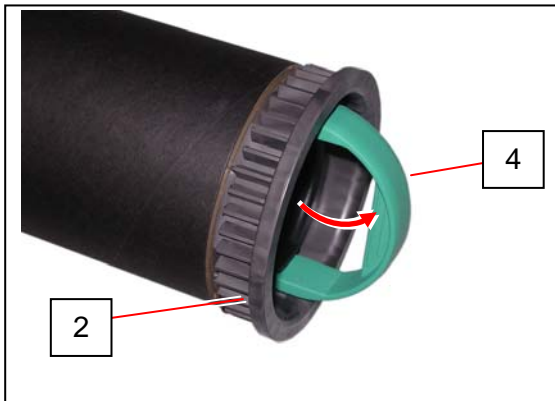

3. Hold the shown part of the right Slide Guide (5). Move it to match your roll media's width. The right and left Side Guides will automatically move together.

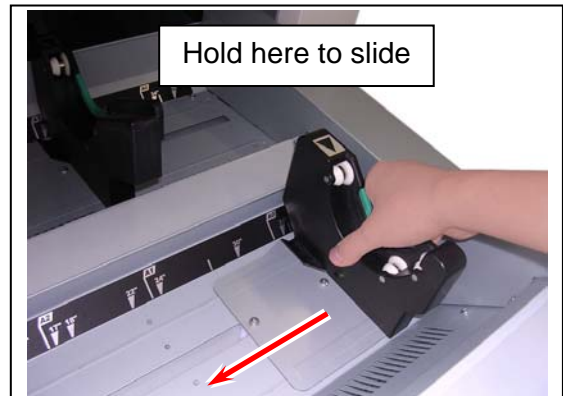
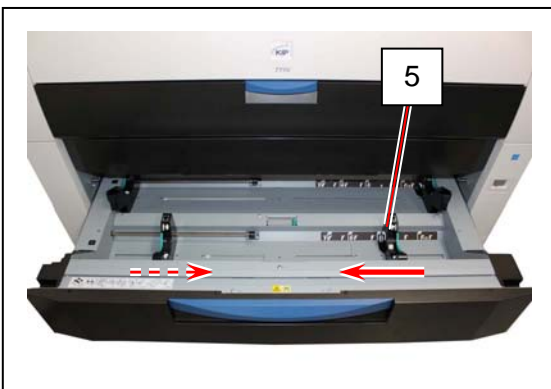

4. Insert each Flange (2) into both ends of the roll media core to be installed.

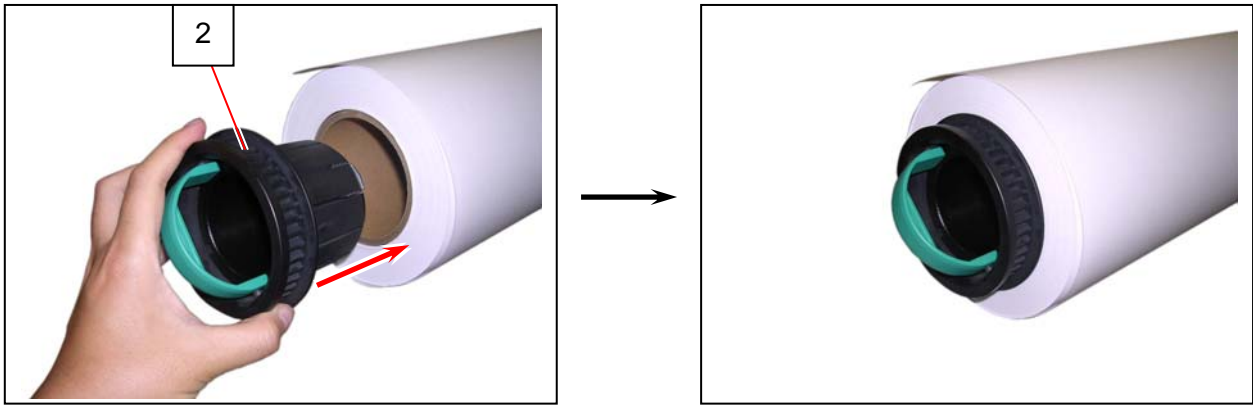

NOTE

(1) Fully insert Flange into the roll media core so that the inside rim of Flange evenly touches the side face of the roll media.

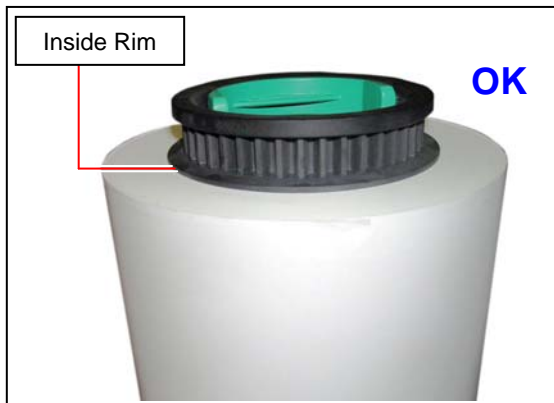

Correct: Fully inserted

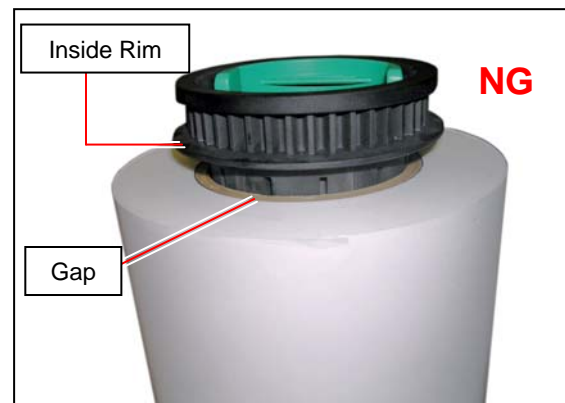

Wrong: not touching roll side

(2) Flange has Stoppers (6) with sharp edge. Be sure not to touch them.

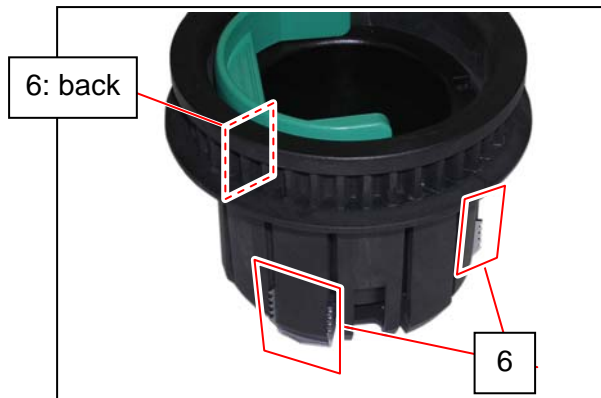

5. Push both the levers (4) down in either way. Position them flat against Flange to secure the roll media.

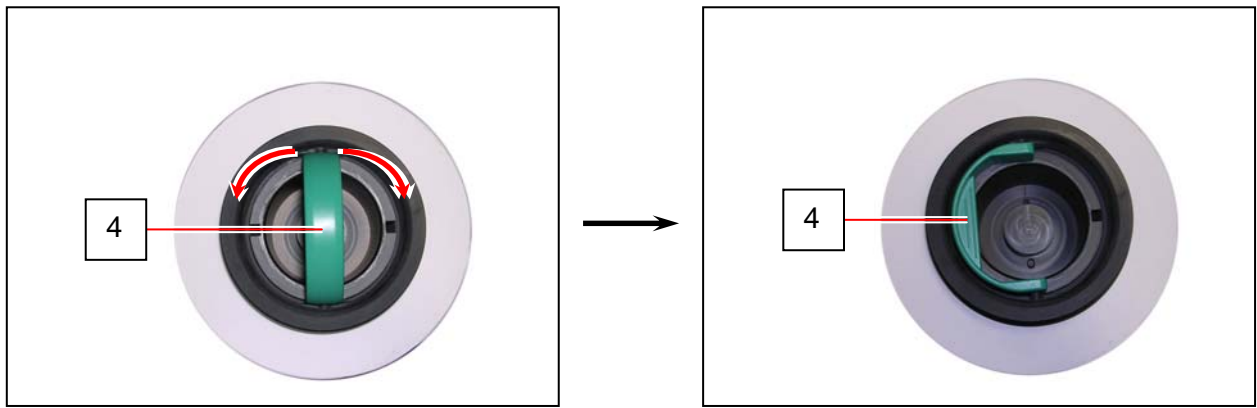

6. Lift the roll media by holding both Flanges. Lower Flanges onto Slide Guides (5).

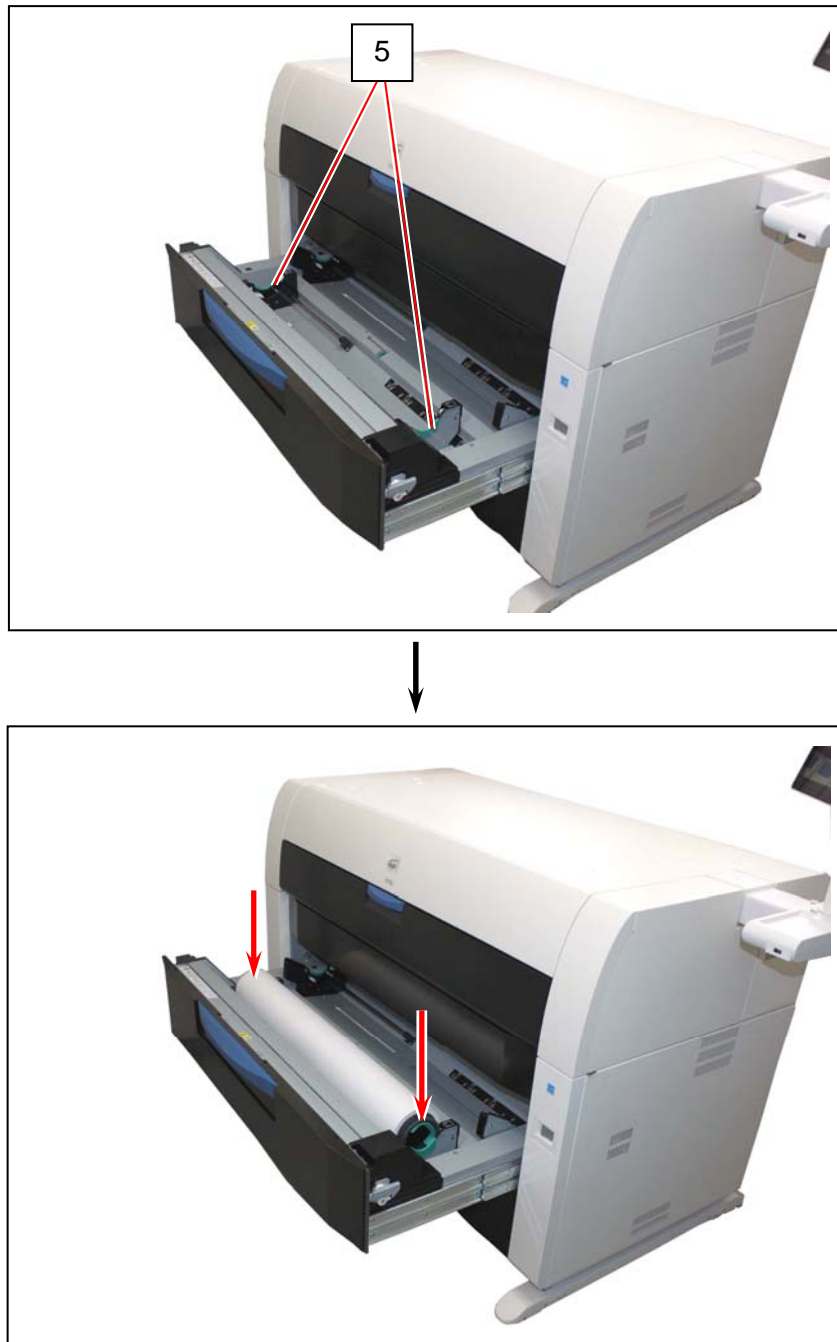

NOTE

(1) Note the rewinding direction.

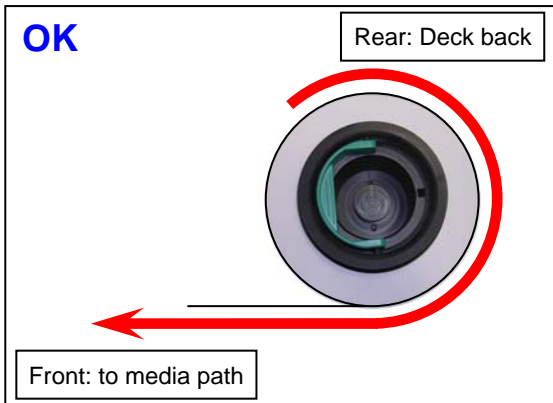

Correct: Edge comes from bottom

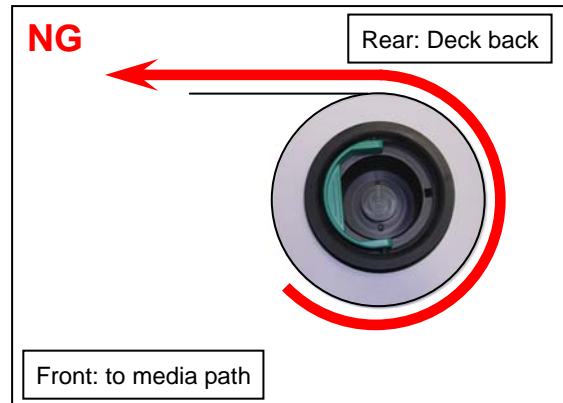

Wrong: Edge comes from top

(2) The outside rim (7) of Flange should meet the black triangle (8) marked on Slide Guide. Otherwise the roll media may fall in Roll Deck or result in an incorrect media feeding.

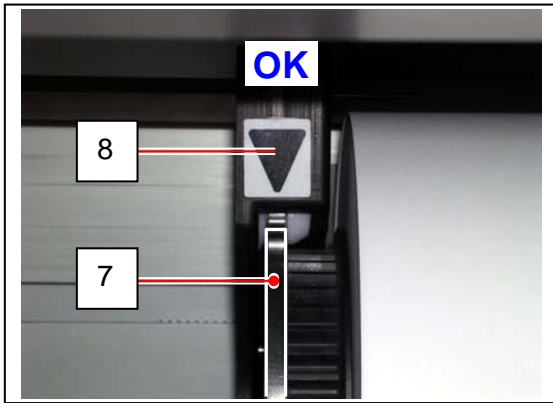

Correct

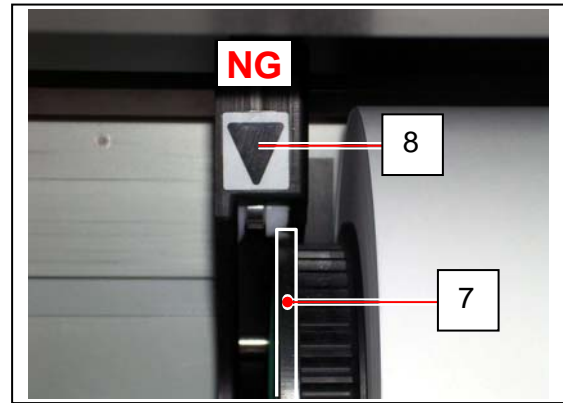

Wrong

7. Insert the leading edge under Guide Plate (9) until it touches the feeding roller (10).

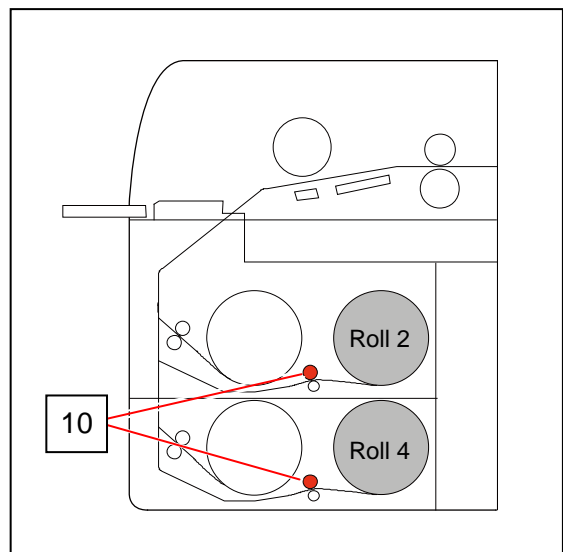
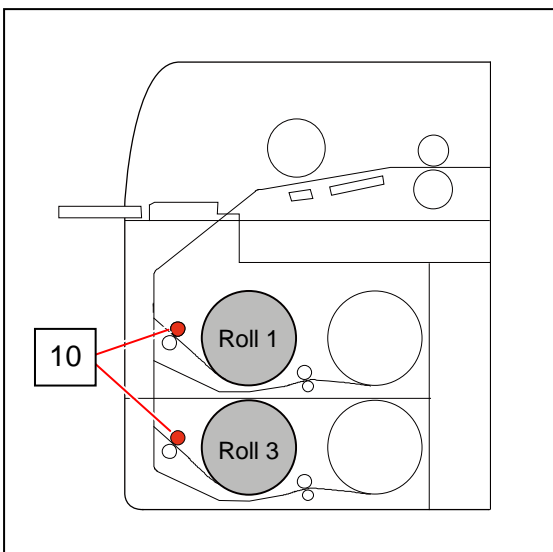
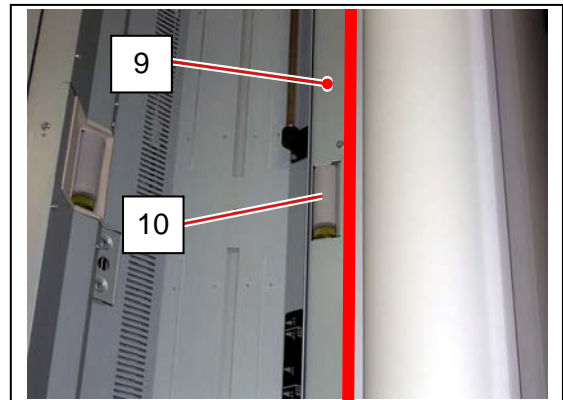
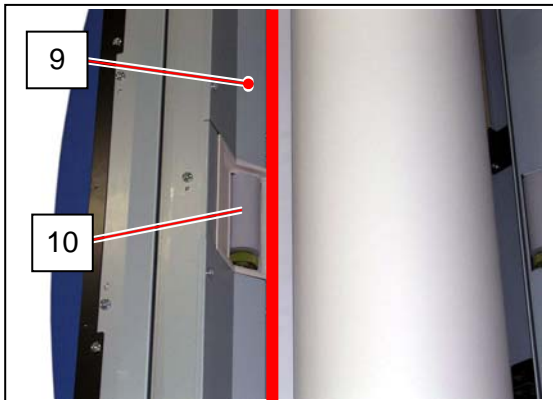
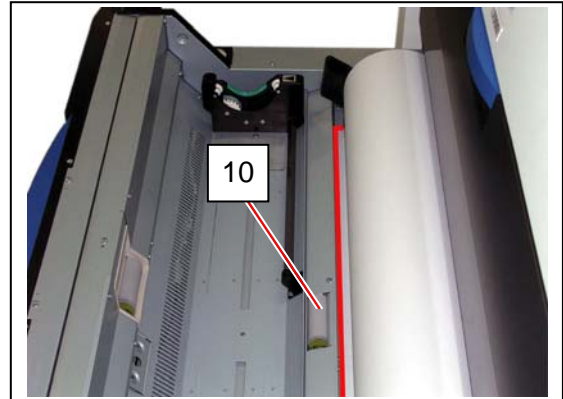
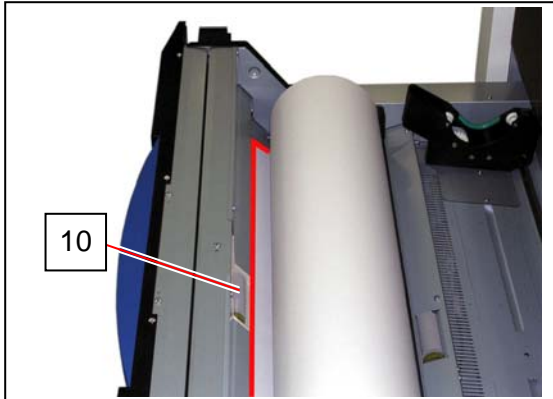
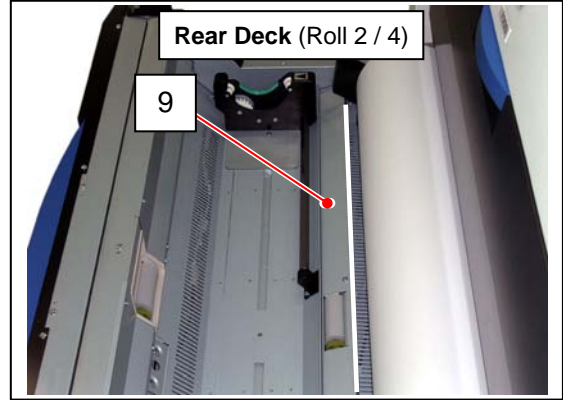
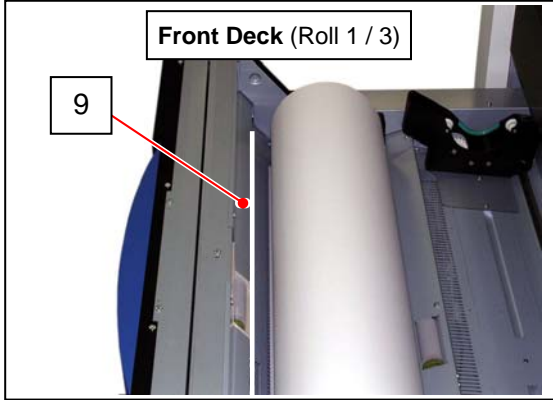

8. Rotate the green knob (11) to the arrow direction (away from front) so that the feeding rollers catch the leading edge.

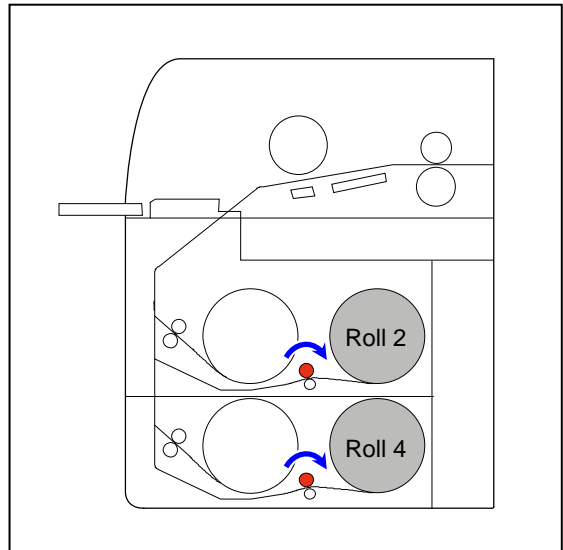
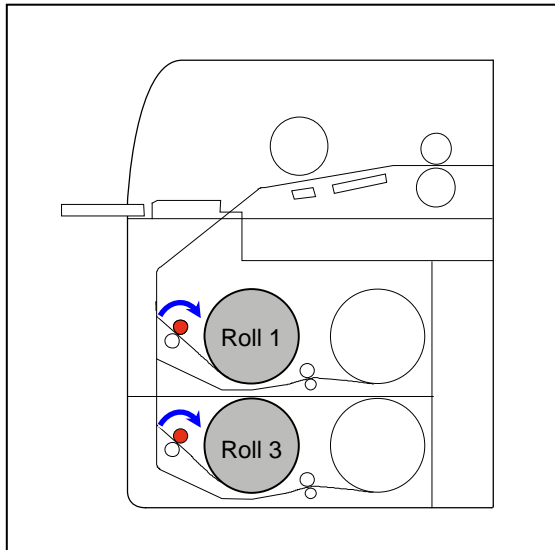
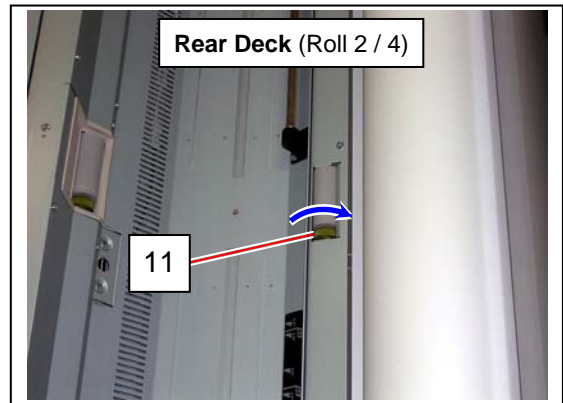
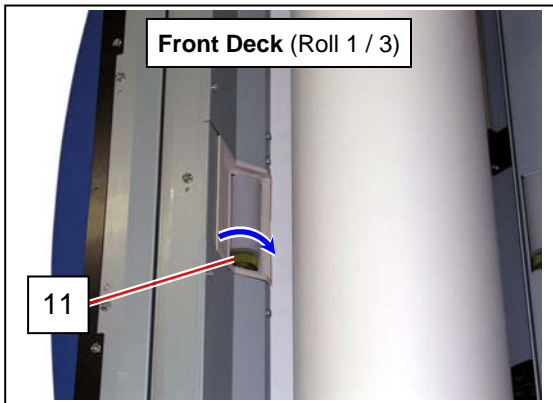

9. Push Roll Deck (1) to firmly close it.

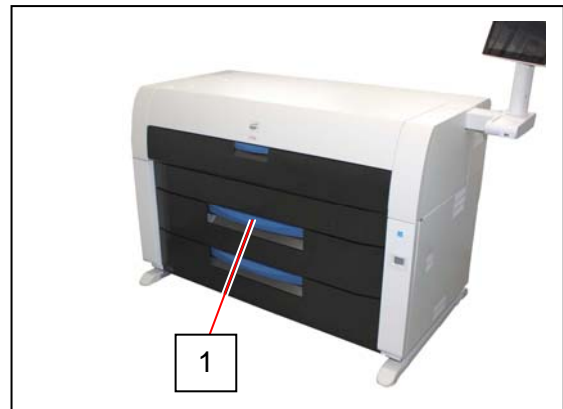
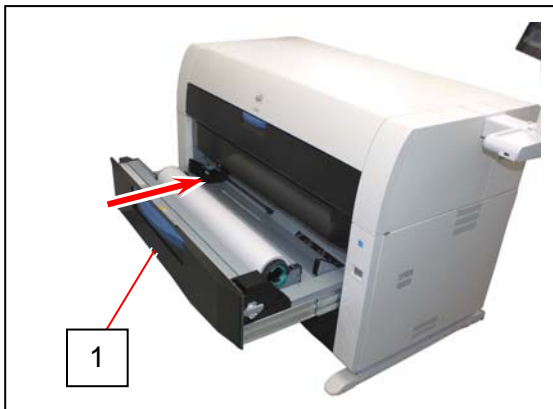

⚠ NOTE

- (1) Be sure to close Roll Deck fully until it locks at the correct position.
A paper jam may occur if it is not locked firmly.
- (2) Be sure not to catch your finger in between Roll Deck drawers.

10. When you close Roll Deck, "MEDIA" screen will appear on the UI screen. Choose the correct roll width and type, and press "Initial Cut" button (with scissors icon) for the corresponding Roll Deck.

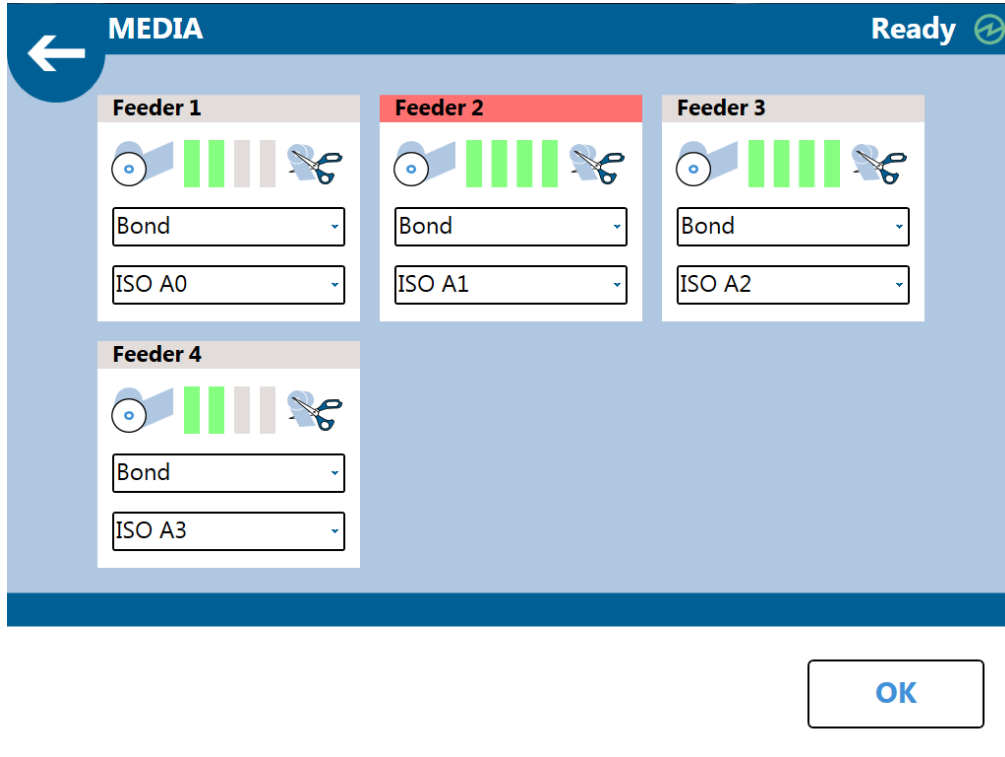

2. 4 Replacing Toner Cartridge

⚠ WARNING

There is combustible powder in the toner cartridge.
Do not burn up the used toner cartridge.

Reference

When the toner is empty, the UI Screen will display Toner Empty sign.
Follow the later procedure (or as noted in the UI's User Guide) to replace the Toner Cartridge with a new one (genuine).

⚠ NOTE

- (1) The KIP 7970 will indicate Toner Empty sign if an incorrect toner cartridge or no toner cartridge is installed to the printer.
- (2) At the machine's installation, some amount of initial toner powders will be supplied to the machine. Thus Toner Empty sign might appear slightly earlier for the first installed toner cartridge than usual.

1. Open the Manual Table (1).

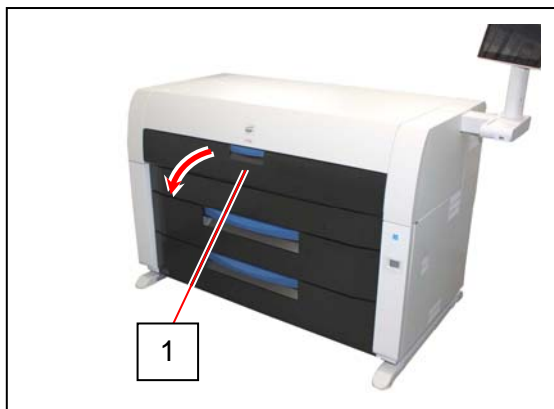

2. Pull out the Upper Frame Unit (2) to your side (front) with holding both handles (3).

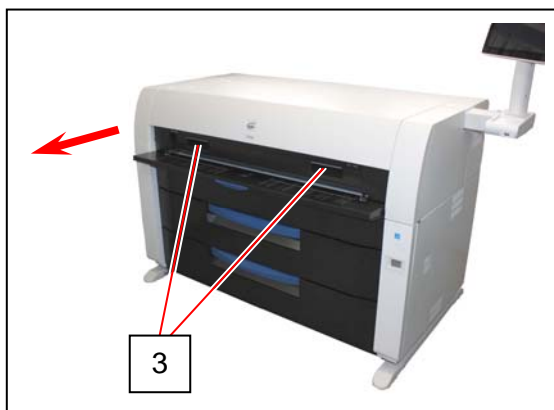

3. Push the Joint (4) rightward to release the Toner Cartridge.
(The joint will be latched on the right.)

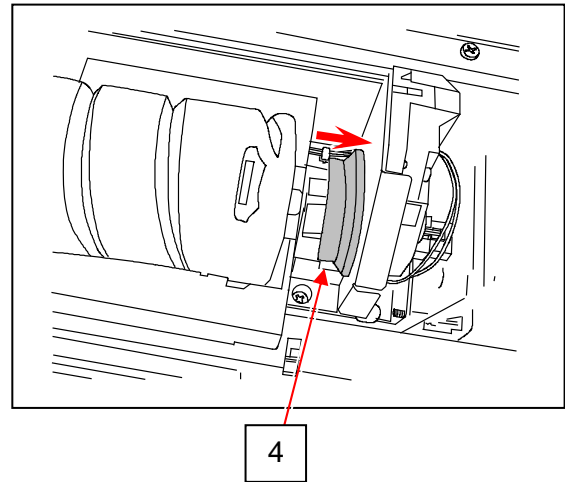

! NOTE

Slide the Joint until it clicks to unlock the toner cartridge.
Not doing so may damage the toner supply system.

4. Pressing down the green lever, rotate Toner Cartridge body (**not the Cap of Cartridge**) to the arrow direction until it stops. This will close the toner supply opening on Toner Cartridge.

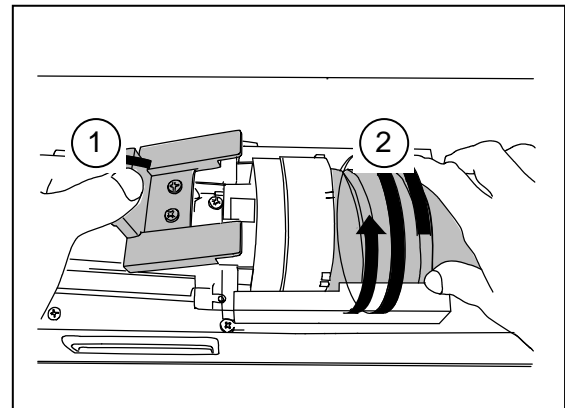

5. Keep pressing the green lever. Lift up Toner Cartridge and remove it.

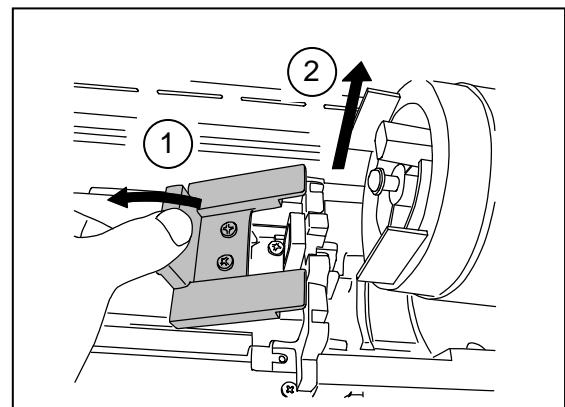

! NOTE

If your hand or your clothing is soiled by toner, dust the toner.
If it is unable to dust it, wash the clothing with the cold water.
(Do not use the hot water at this time because the toner will soak into fiber.)

6. Peel off the wrap on the toner supply hole of Toner Cartridge.
Shake a new Toner Cartridge several times right and left to make the toner smooth.

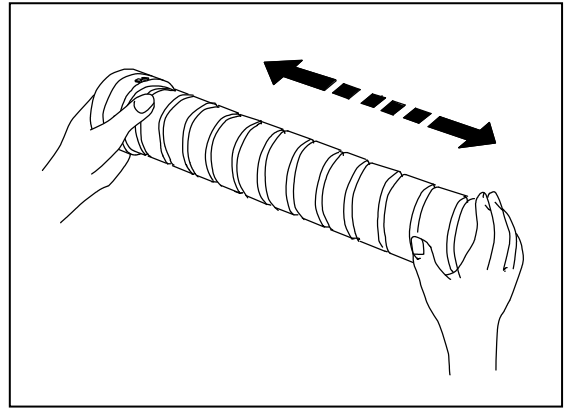
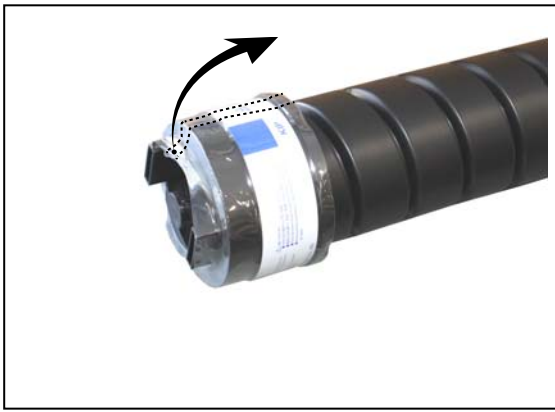

7. Press the green lever down until it clicks. Insert the far left pin on Toner Cartridge into the slot firmly. (Please direct the opening on Toner Cartridge downward at this time.)

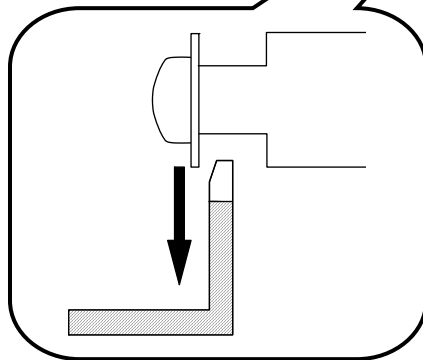
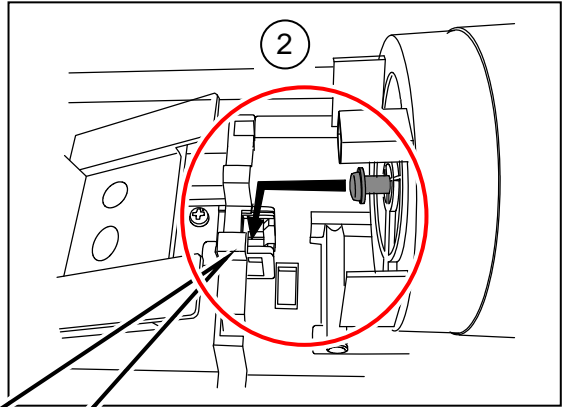
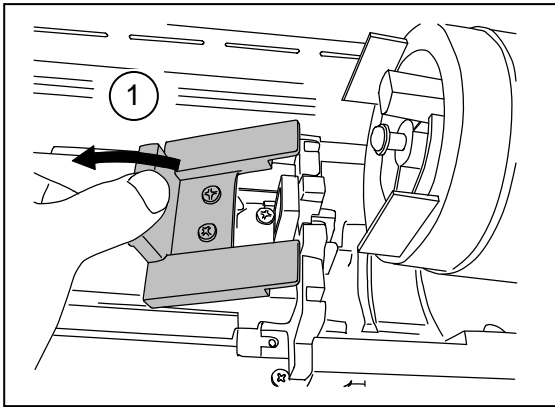

NOTE

Please confirm that the green lever firmly locks the Toner Cartridge at the correct position. (It must be at a level position.)

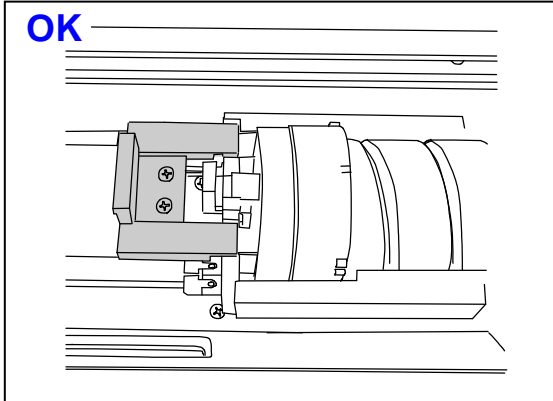

Correct: Green Lever in position

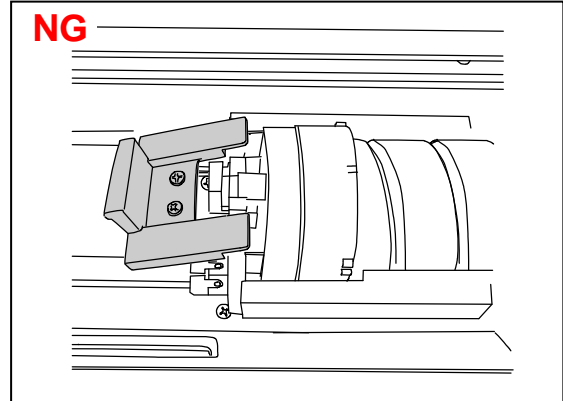

Wrong: Toner Cartridge not locked

8. Slightly pull Toner Cartridge rightward and insert the swelling tab in the arrowed slot.

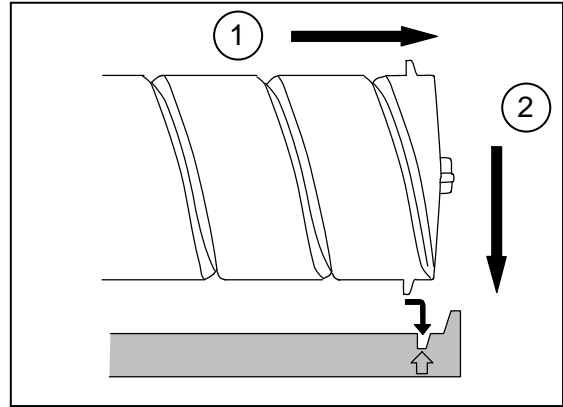

9. Rotate Toner Cartridge to the arrow direction in 180 degrees or more.
(The new Toner Cartridge is closed firmly so as not to lose the toner during the transportation)

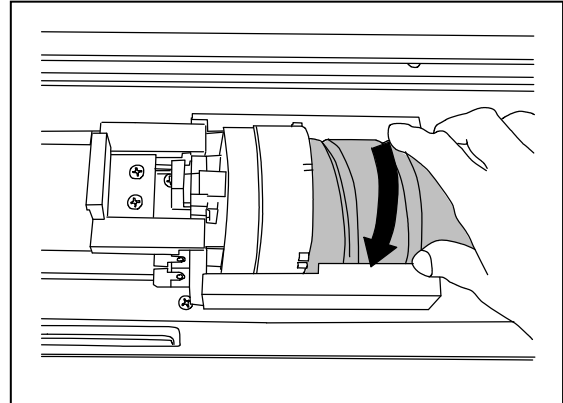

! NOTE

Even if the Joint is not fit to the Toner Cartridge, when you turn on the printer, it is automatically fit properly.

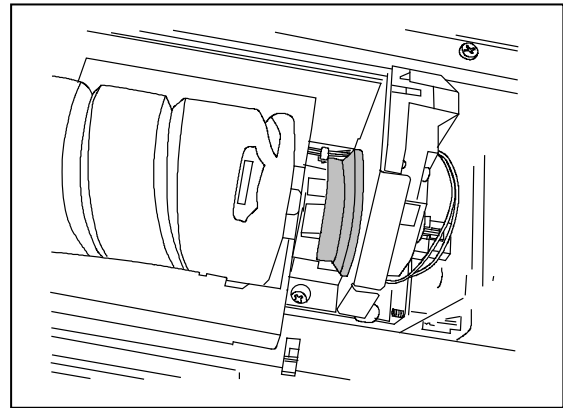

10. Push in Upper Frame Unit (2) firmly. Close the Manual Table (1).

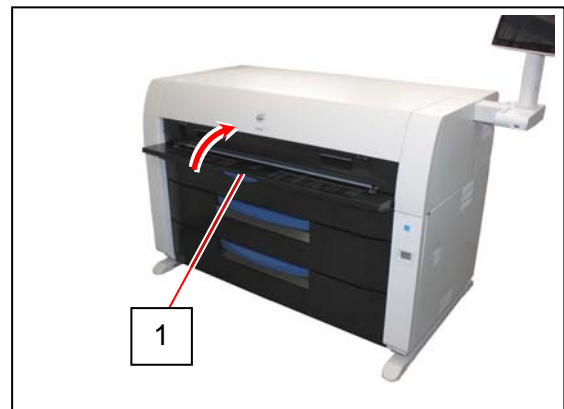
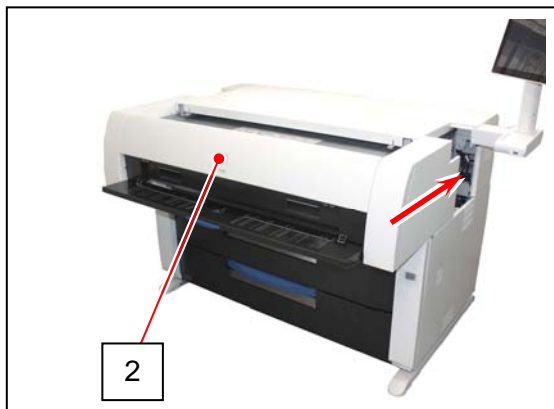

2.5 Placing Cut Sheet Media

1. Open Manual Table (1).

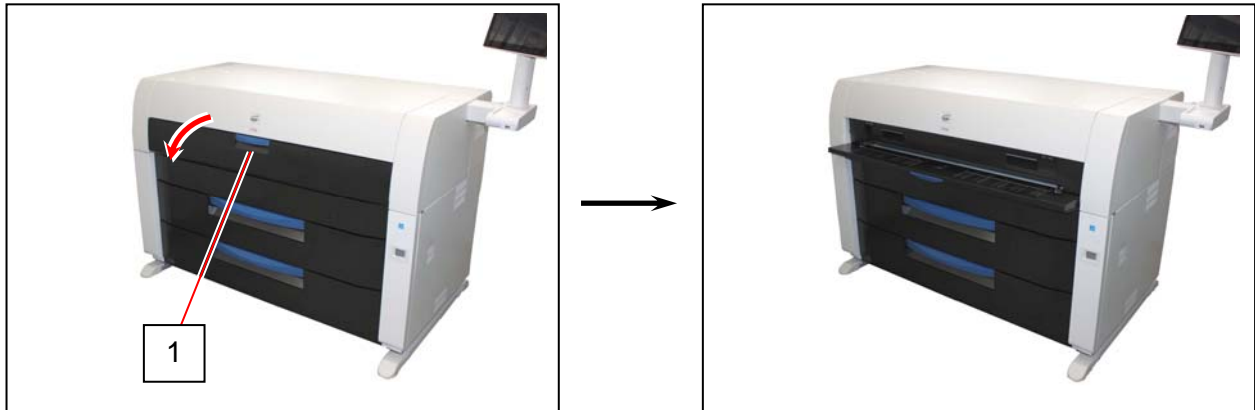

2. There are several size markings on Manual Table which indicate possible feed positions. Place a cut sheet in a required size on the table between its concerning size markings then insert it into Manual Feeder.

When the leading edge touches the feeding roller, the machine automatically carries and sets the sheet at the proper position.

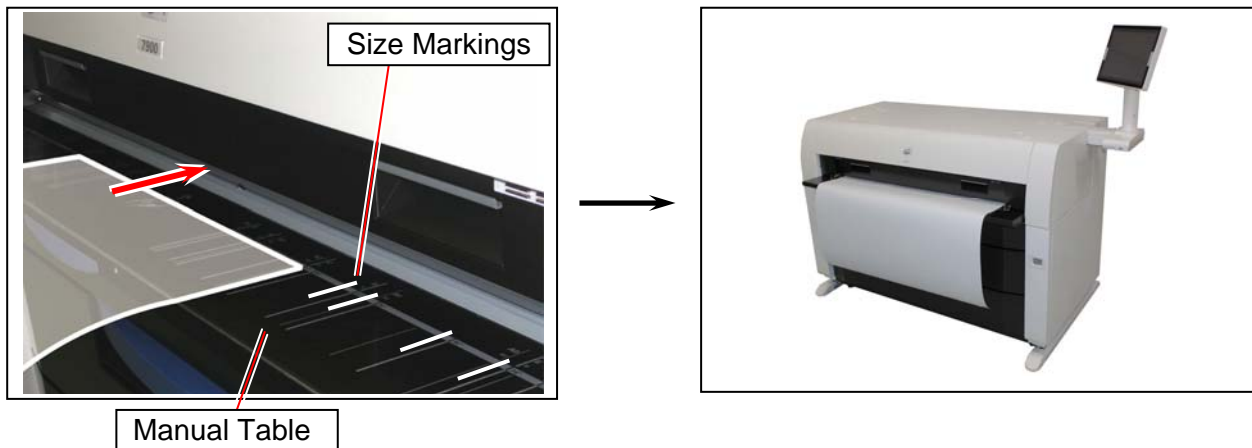

! NOTE

- (1) As a curly cut sheet will cause a mis-feed, straighten the sheet as far as possible before printing. And set the sheet in "curl down" direction as a mis-feed can be avoided. "Curl up" sheets tend to result in a mis-feed.



Correct (curl down)



Wrong (curl up)

- (2) Setting a cut sheet to the bypass feeder while printing may cause a paper jam. Be sure to check the printer is idle (not processing a print job) before setting a cut sheet.

2. 6 Copying (for MFP Model)

Please refer to the detailed procedure for making a copy, which is included in "GUIDES" in UI Home screen as well.

1. Press [COPY] in UI Home screen.

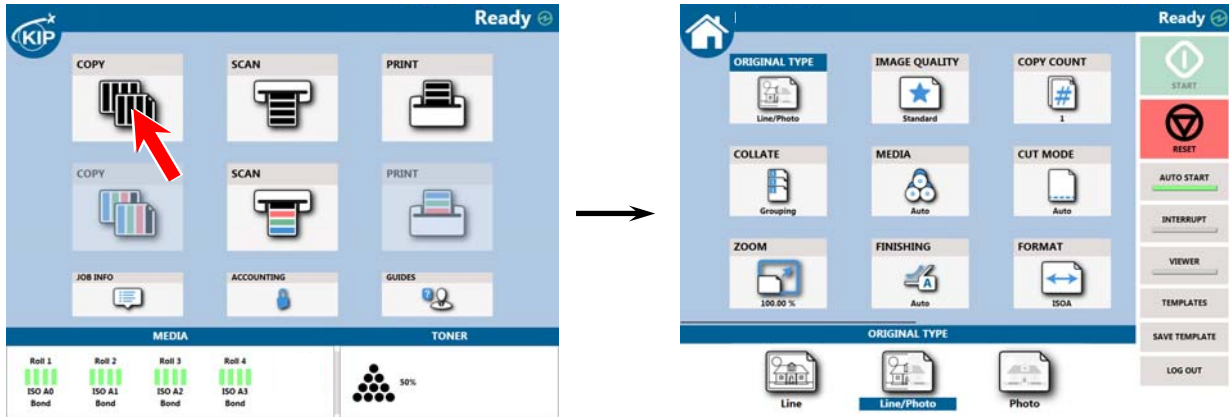

The UI screen may vary depending on your system configuration.
(Shown with available options)

2. There are several size markings on Original Table which indicate possible feed positions.
Line up Original Guides (1) with the proper markings according to the original width.

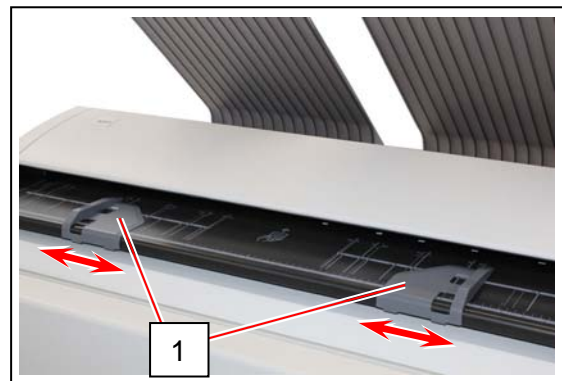

3. Place the original on the Original Table with face up.
Then insert it under the Scanner Unit along with Original Guides.
When the leading edge touches the original feeding roller, the machine automatically carries and sets the original at the proper position.



4. The Printer will start the copy process.

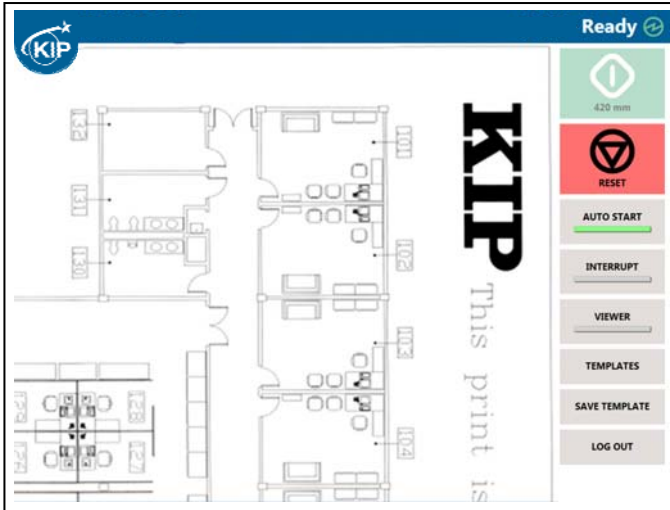

Reference

Pressing START button may be required to start the scan according to the scanner's controller software. For further details of "Auto Start", see the software's document.

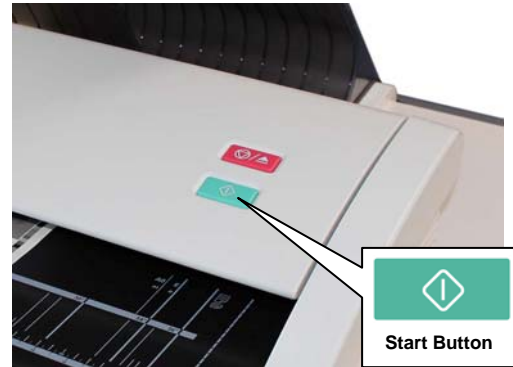

NOTE

The scanner unit does not accept originals automatically during Sleep Mode. Tap on the UI screen and then insert an original.

The KIP 7970 Series has 2 print delivery system, the print tray / rear stacking equipment.



NOTE

For the front stacking, gently lift up the prints on the print tray to the arrow direction to avoid rubbing the print surface. A large number of prints should be removed in several sheets.

OK



Correct: Gently lift up and remove

NG

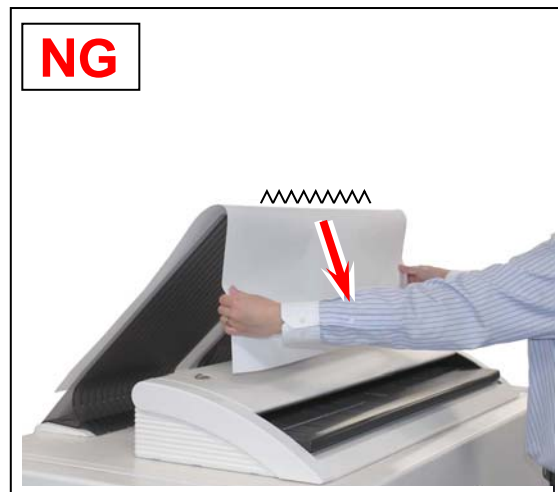

Wrong: Do not pull downward

For the front stacking, the printer will inform you of “Upper Bin Full” on exceeding capacity of stacking. If the UI screen shows “Upper Bin Full”, remove all the prints on the print tray.

For further information of switching front / back delivery, see KIP Multi-Touch User Guide.

2.7 Stop of Scan or Copy (for MFP Model)

1. If necessary, press the Scan Abort Button on the Scanner Unit to immediately stop the original while making a copy or scan.



Pressing the button stops the current reading a document immediately. The current printing is stopped as well and is ejected.

NOTE

Do not pull back or hold down the original on Original Table as an attempt to stop feeding it through Scanner Unit.

2. 8 Dehumidifying Roll Media

If the roll paper is extremely humid, it may cause poor prints. You will experience most likely “creasing” and “voids”.

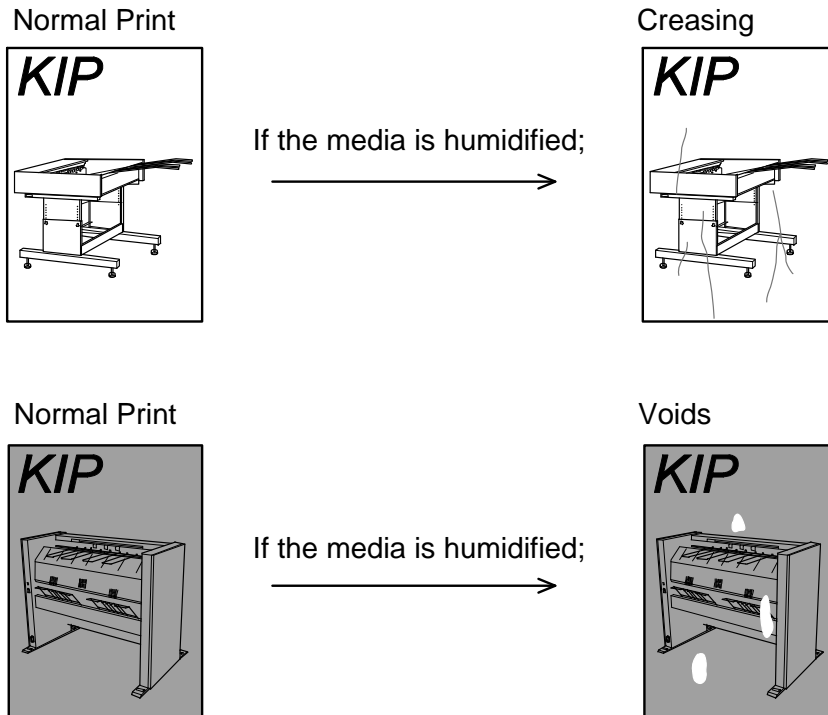

NOTE

Re-appearance of image (especially solid black image) may occur if you print with a humidified film.

When film is installed under the high humidity environment (higher than 60%RH), we also recommend that you turn on the Dehumidify Heater.

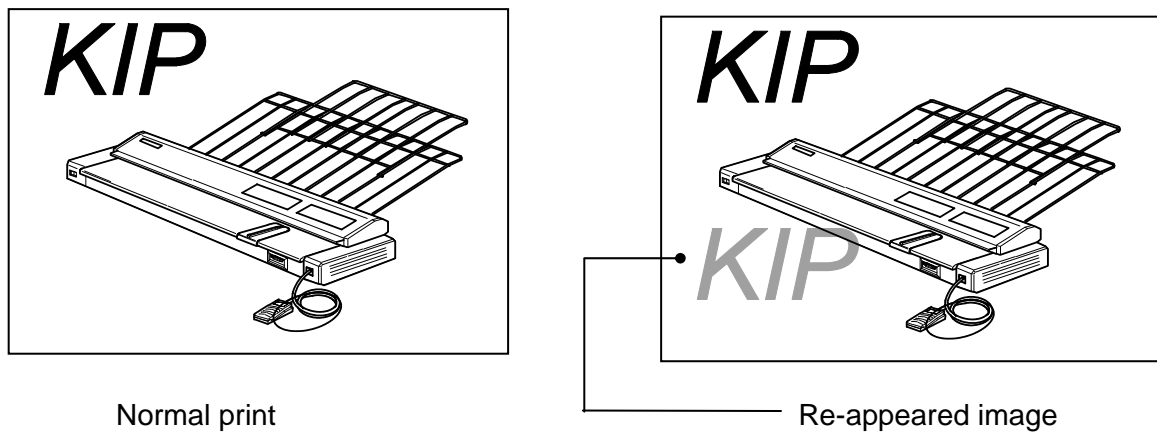

Turn on the Dehumidify Heater if the room air has too much humidity (65% or higher) to prevent the above kinds of print defect. You may be able to fix the above kinds of problem.

! NOTE

- (1) There are several dehumidifying settings which can be set by service personnel. When these settings are determined, the dehumidifier functions. With any setting, the printer must be plugged in and the switch noted above must be in the "H" position.
Call your service personnel if you would like to change the switch setting. Note that the user can not change the setting.
- (2) To achieve the best image quality, we recommend that you use media that is unpacked from the manufacture right before installing it into the printer. If media is unpacked long before installation, poor image quality may occur.

"Dehumidify Heater Switch" is located on the left-rear side of the machine. Press "H" to turn on the Dehumidify Heater.

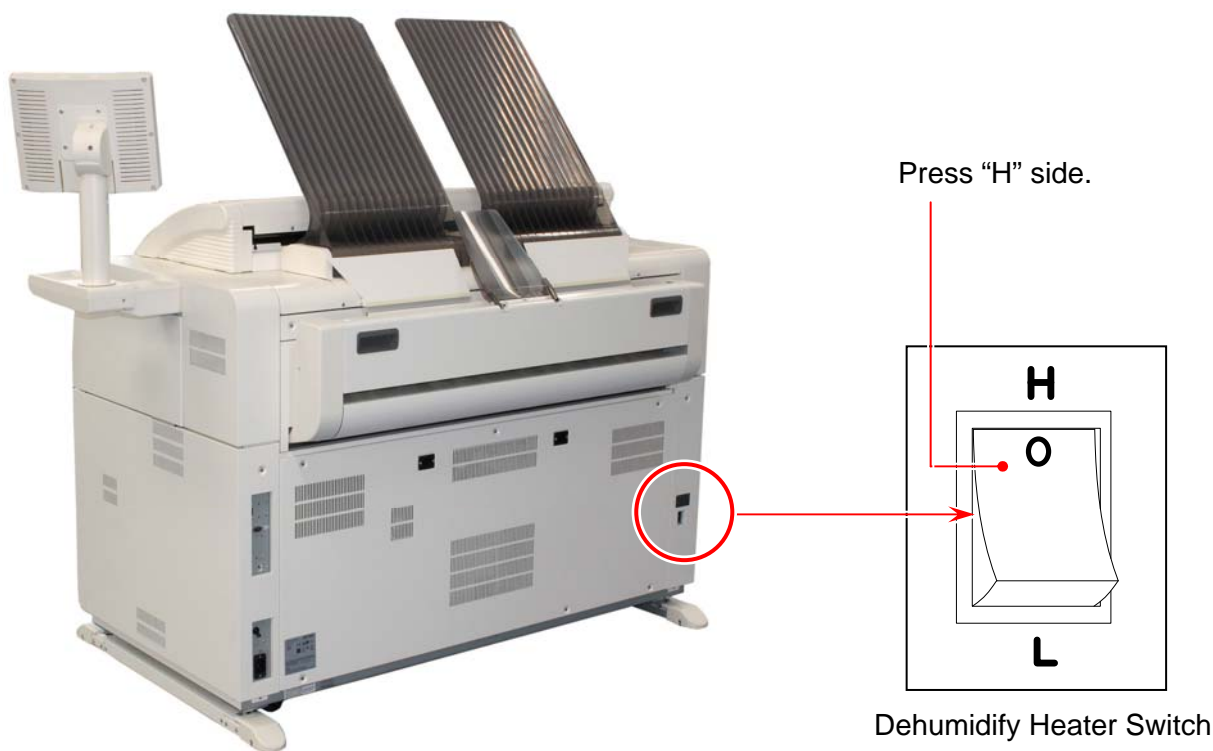

Chapter 3

Error Correction

	Page
3.1 Paper Jam	3- 2
3.1.1 Roll Deck Section Jam (Deck 1, 2 Mis-feed)	3- 3
3.1.2 Manual Feeder Section Jam (By-Pass Mis-feed, Registration Mis-feed)	3- 5
3.1.3 Media Feed Section Jam (Mid Feed Mis-feed, Registration Mis-feed, Separation Mis-feed)	3- 6
3.1.4 Fuser Section Jam (Exit Back Mis-feed)	3- 9
3.1.5 Stack Jam	3- 14
3.1.6 Original Jam (for MFP Model)	3- 15
3.1.7 Outer Device	3- 15
3.2 Door Open	3-16
3.2.1 Roll Deck (Deck 1, 2 Open)	3-16
3.2.2 Upper Frame Unit / Top Cover (Front Cover Open)	3-17
3.2.3 Paper Exit Door (Paper Exit Door Open)	3-18
3.2.4 Scanner Unit (Scanner feeder open) (for MFP Model)	3-18
3.3 Other Operator Call	3-19
3.3.1 Roll Replacement	3-19
3.3.2 Toner Empty	3-19
3.4 Service Call Errors	3-20

3.1 Paper Jam

"Paper Jam" is displayed in the UI screen when the media is jammed.

The jammed location when displaying "Paper Jam" is shown below.

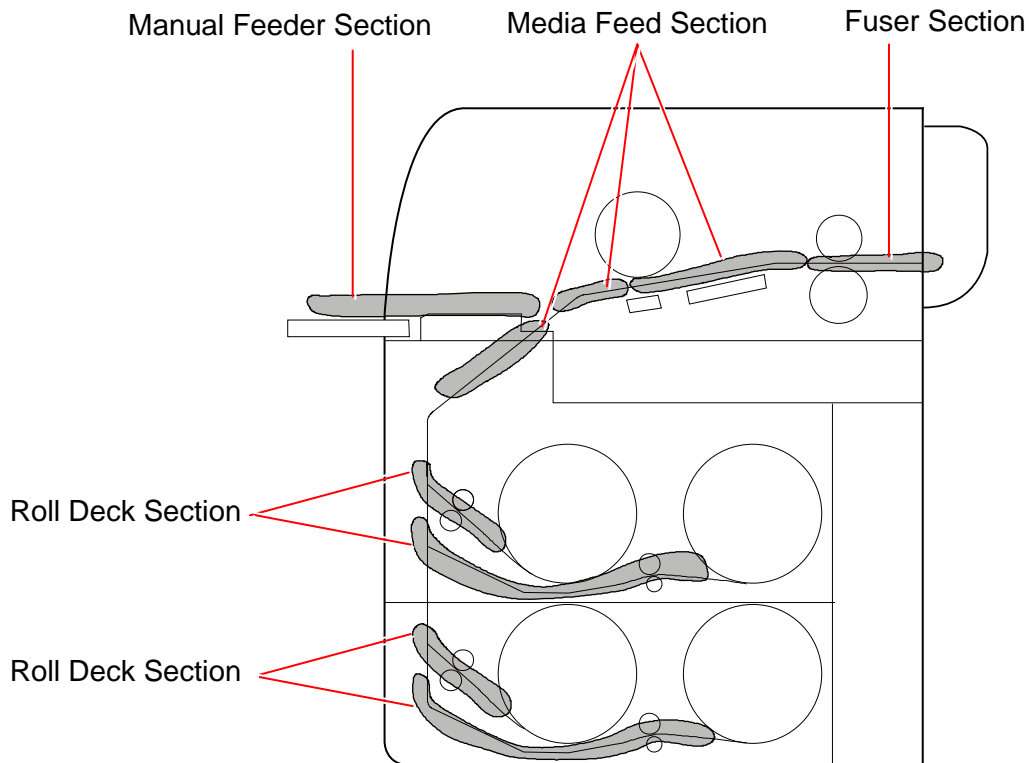

⚠ NOTE

- (1) Be careful not to get paper cuts on your hand.
- (2) Gently remove a jammed paper. When it does not reach Fuser Unit, toner on it may spill off. If toner gets into eyes or your mouth, immediately rinse them with water and contact a doctor.
- (3) Gently remove a jammed paper. When it does not reach Fuser Unit, toner on it may spill off on your cloth. Dust off your cloth. Use cold water to wash in out. Using hot water may leave a stain.

3. 1. 1 Roll Deck Section Jam (Deck 1, 2 Mis-feed)

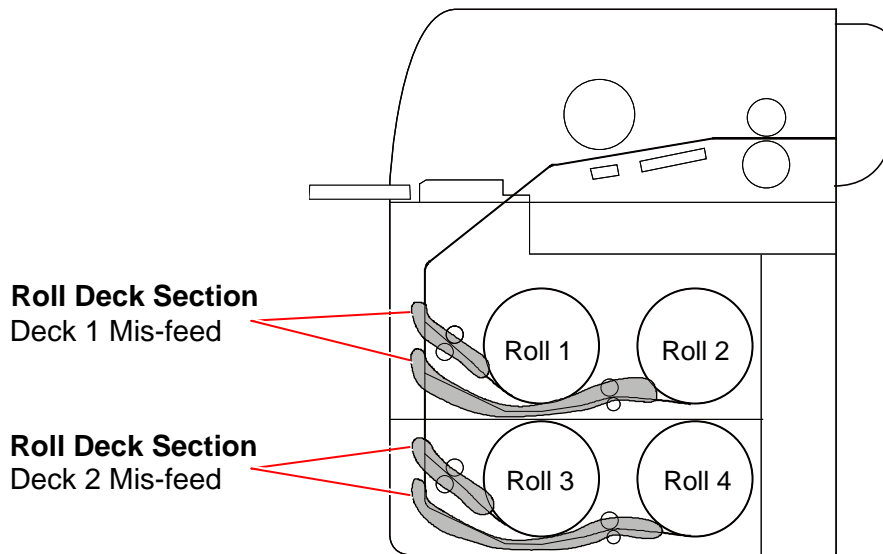

1. Open the Roll Deck in issue. And then rewind the roll onto the media core.



2. If the leading edge of the media is torn or folded, cut it off.

3. Set the roll media correctly.

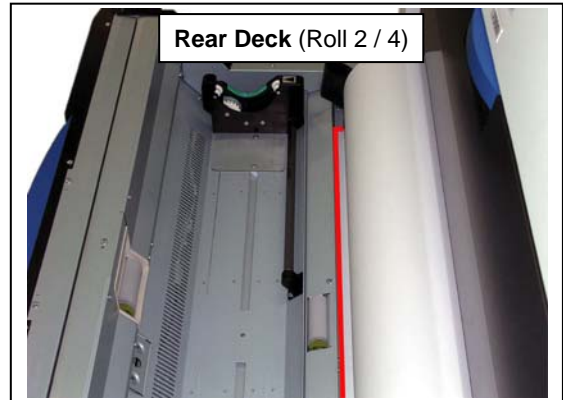
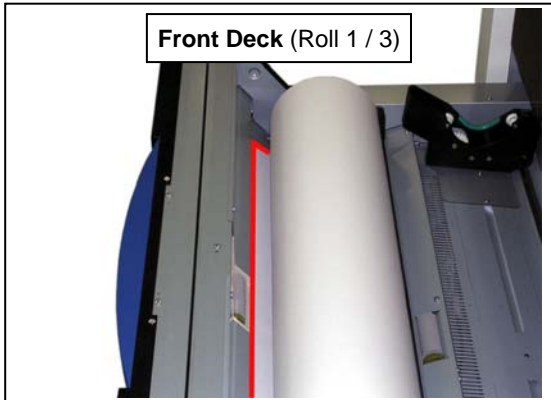
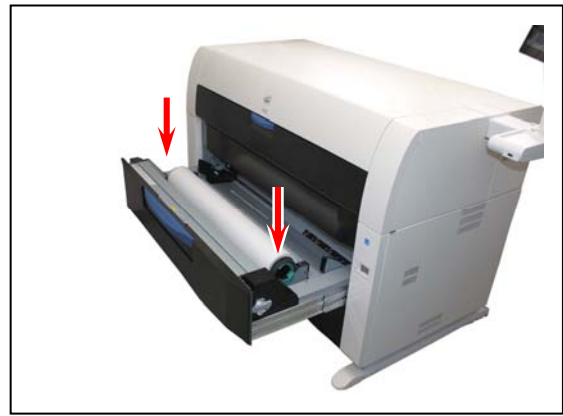

! NOTE

The outside rim of Flange should meet the black triangle marked on Slide Guide. Otherwise the roll media may fall in Roll Deck or result in an incorrect media feeding.



Correct

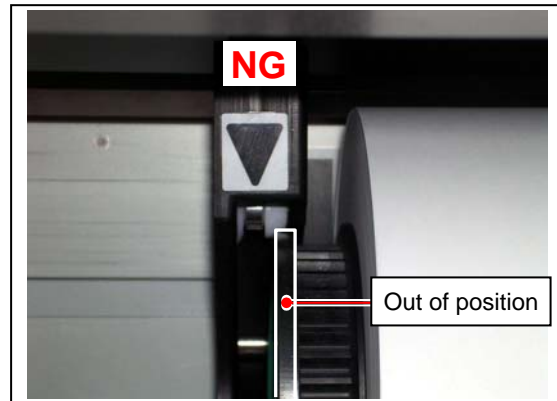

Wrong

4. Close the Roll Deck.



3. 1. 2 Manual Feeder Section Jam (By-Pass Mis-feed, Registration Mis-feed)

Manual Feeder Section

- By-Pass Mis-feed
- Registration Mis-feed

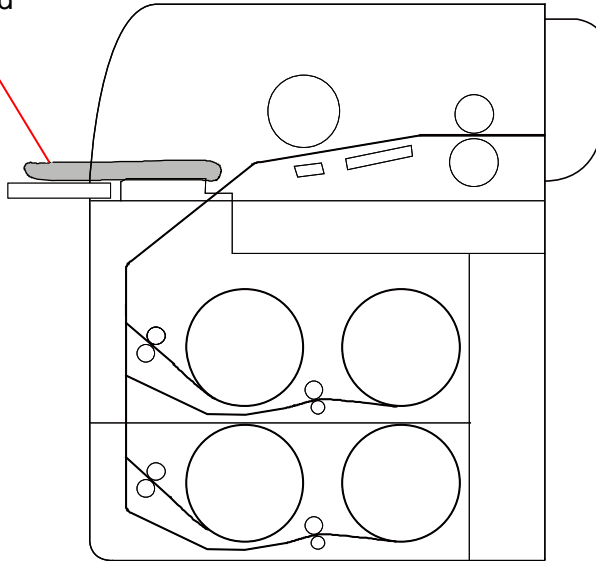

1. Pull out the Mis-feed paper from the Manual Feeder, and if the leading edge of the paper is torn or folded, replace it with a new one.



3. 1. 3 Media Feed Section Jam (Mid Feed Mis-feed, Registration Mis-feed, Separation Mis-feed)

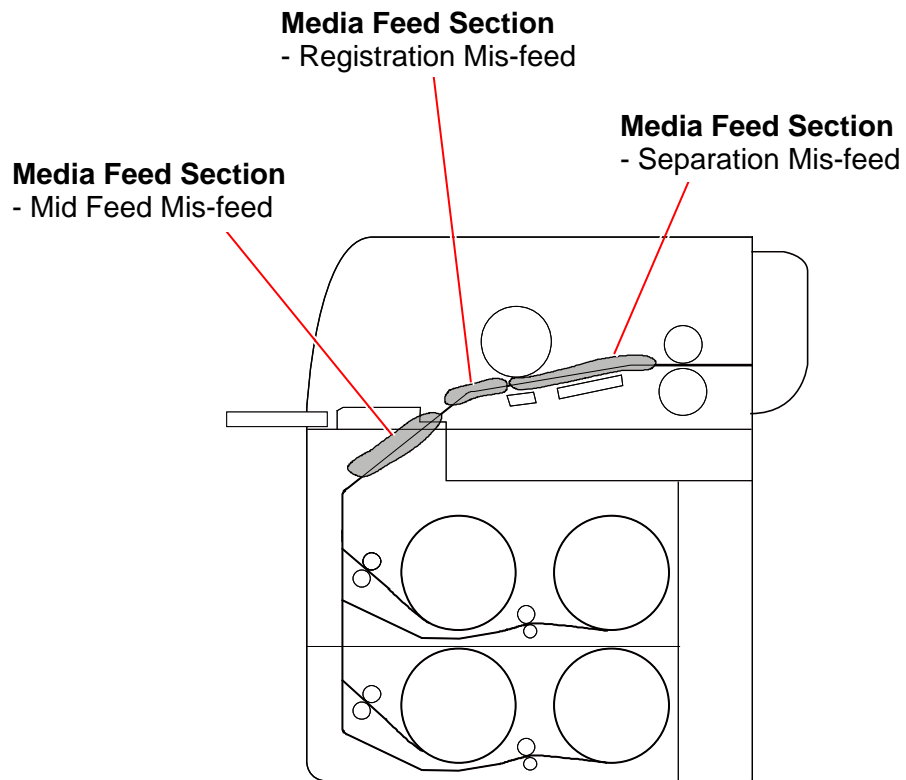

1. Open the Manual Table (1).

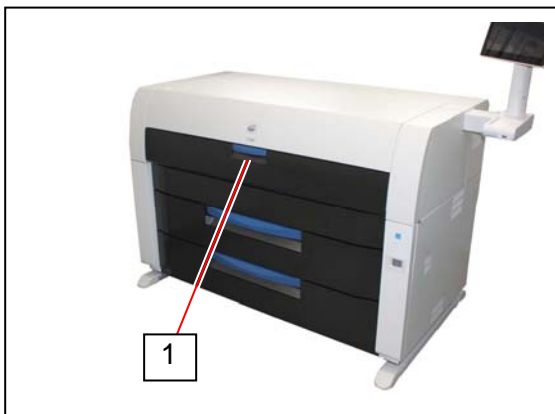

2. Pull out the Upper Frame Unit (3) to your side (front) with holding both handles (2).

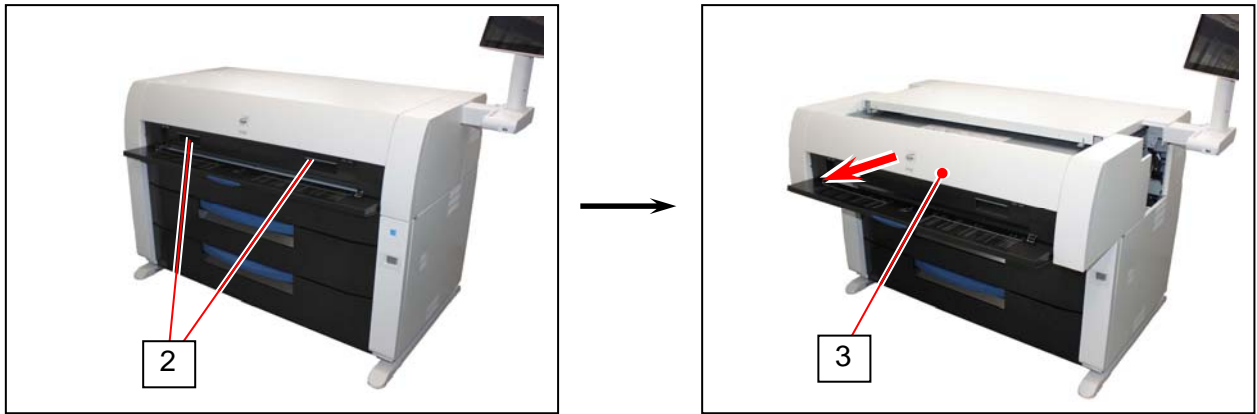

3. Pull up both knobs (4), and then push the Top Cover (5) to rear side.

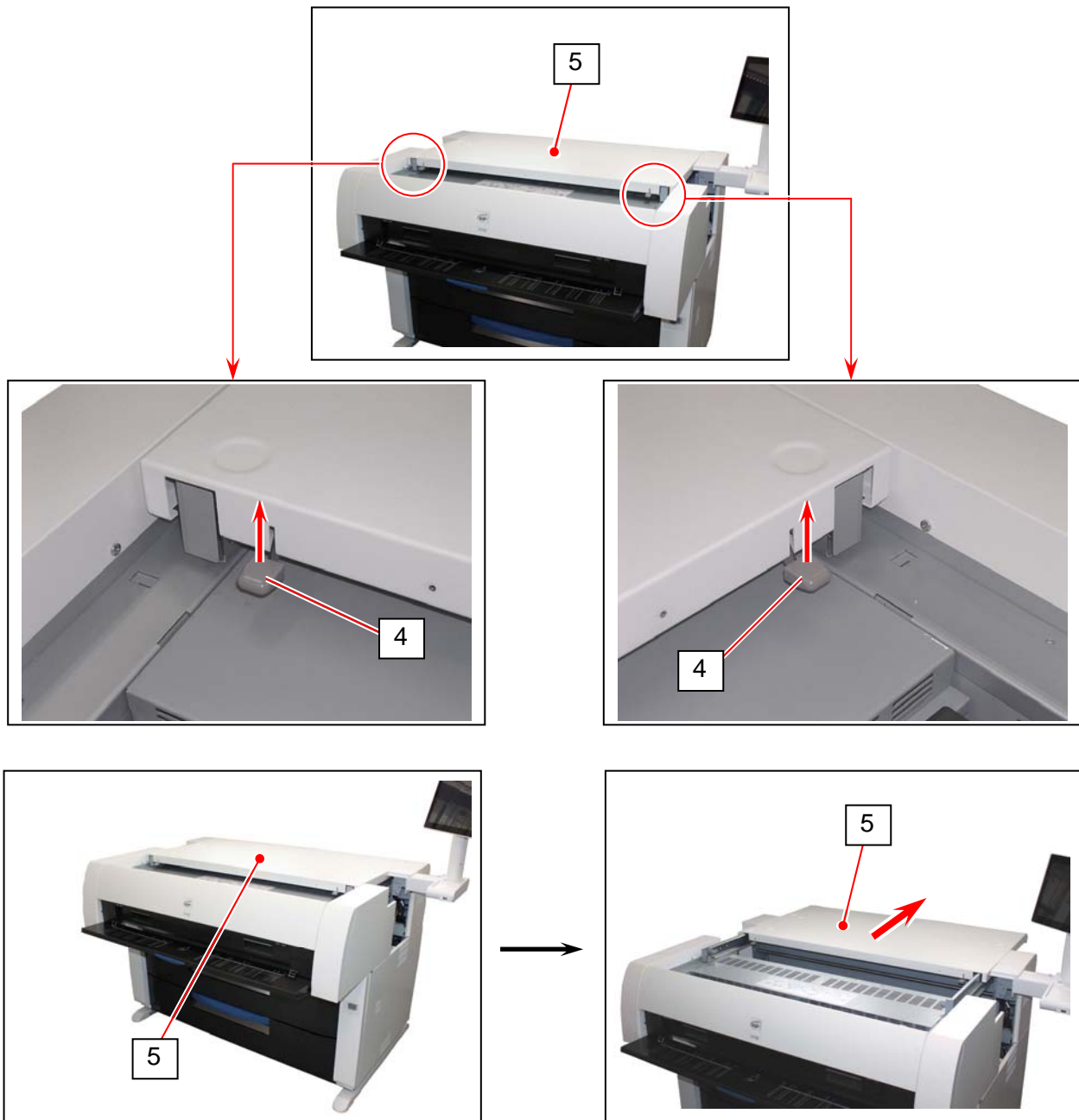

4. Remove the mis-fed paper.

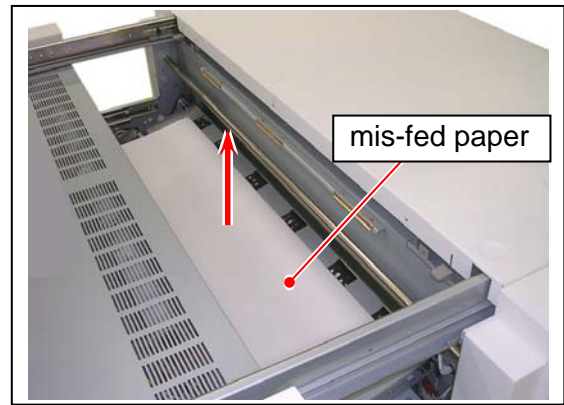

5. Close Top Cover (5).



6. Close Upper Frame Unit (3) and Manual Table (1).

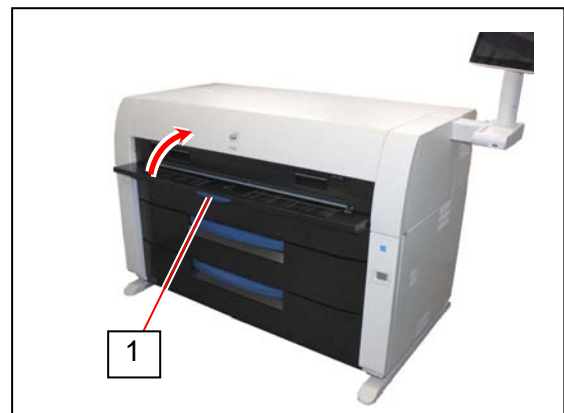

3. 1. 4 Fuser Section Jam (Exit Back Mis-feed)

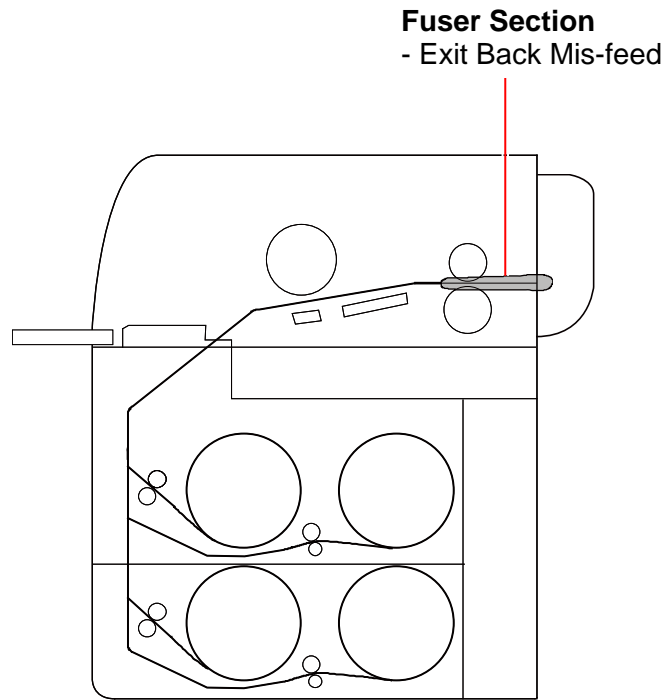

1. Hold the gray handles and open the Paper Exit Door (1).

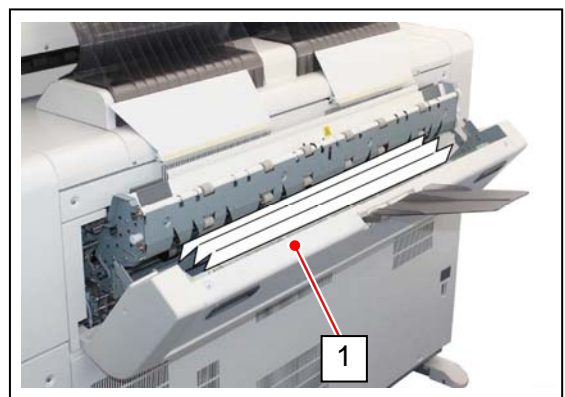

2. Pull and remove the mis-fed paper to the rear.

If you remove the print at this time, just close the Paper Exit Door.
If the print cannot be removed, go to the next step.

If the print (including any torn part) can be removed, go to step 6.

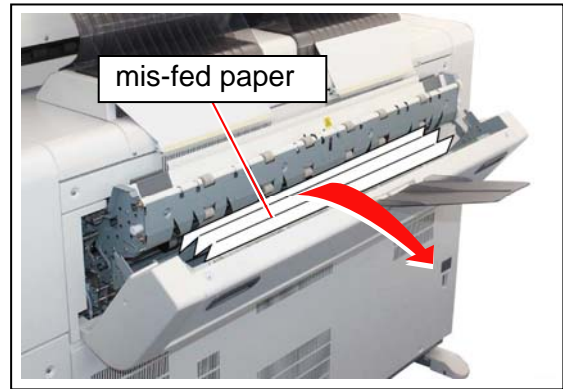

! WARNING

Be careful not to get burnt when you touch the printing paper as it may be very hot.

! NOTE

If removed a mis-fed paper inside the Fuser Door, scattered toner can be adhered to the next print.

4. Hold the gray areas (2) and release the Fuser Door (3).
Pull and remove the mis-fed paper to the rear.

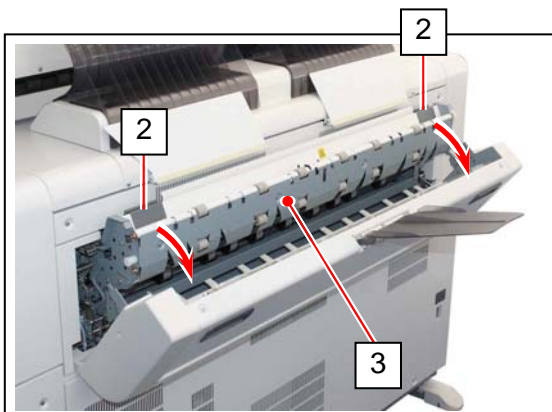

! WARNING

There are extremely hot parts inside the Fuser Door.
Do not touch any parts in the Heater Unit, or you will be burnt.
Also be careful not to get burnt when you touch the printing paper as it may be very hot.

! NOTE

If removed a mis-fed paper inside the Fuser Door, scattered toner can be adhered to the next print.

5. Close Fuser Door (3) and Paper Exit Door (1).

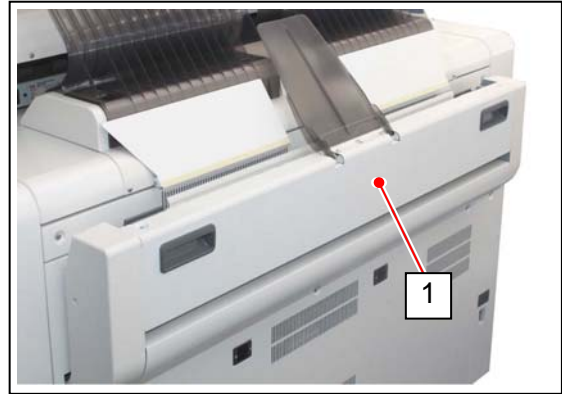
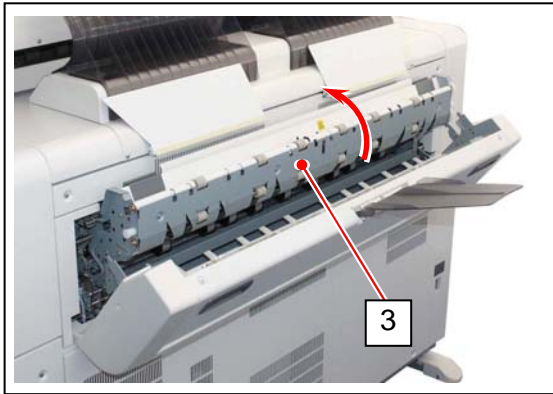

6. Open the Manual Table (4).

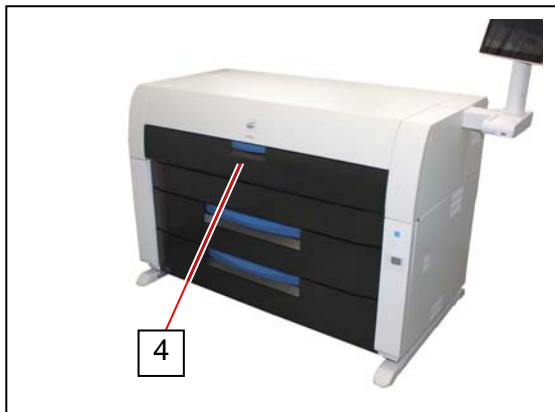

7. Pull out the Upper Frame Unit (5) to your side (front) with holding both handles (6).

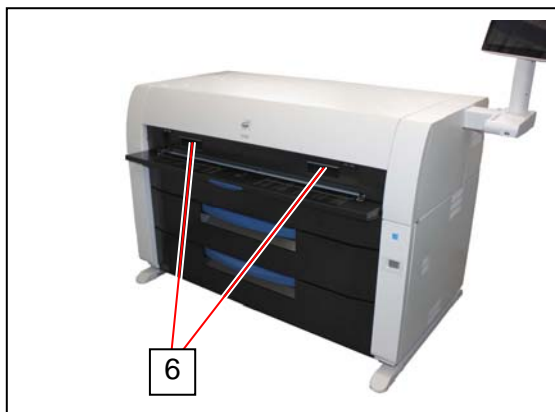

8. Pull up both knobs (7), and then push the Top Cover (8) to rear side.

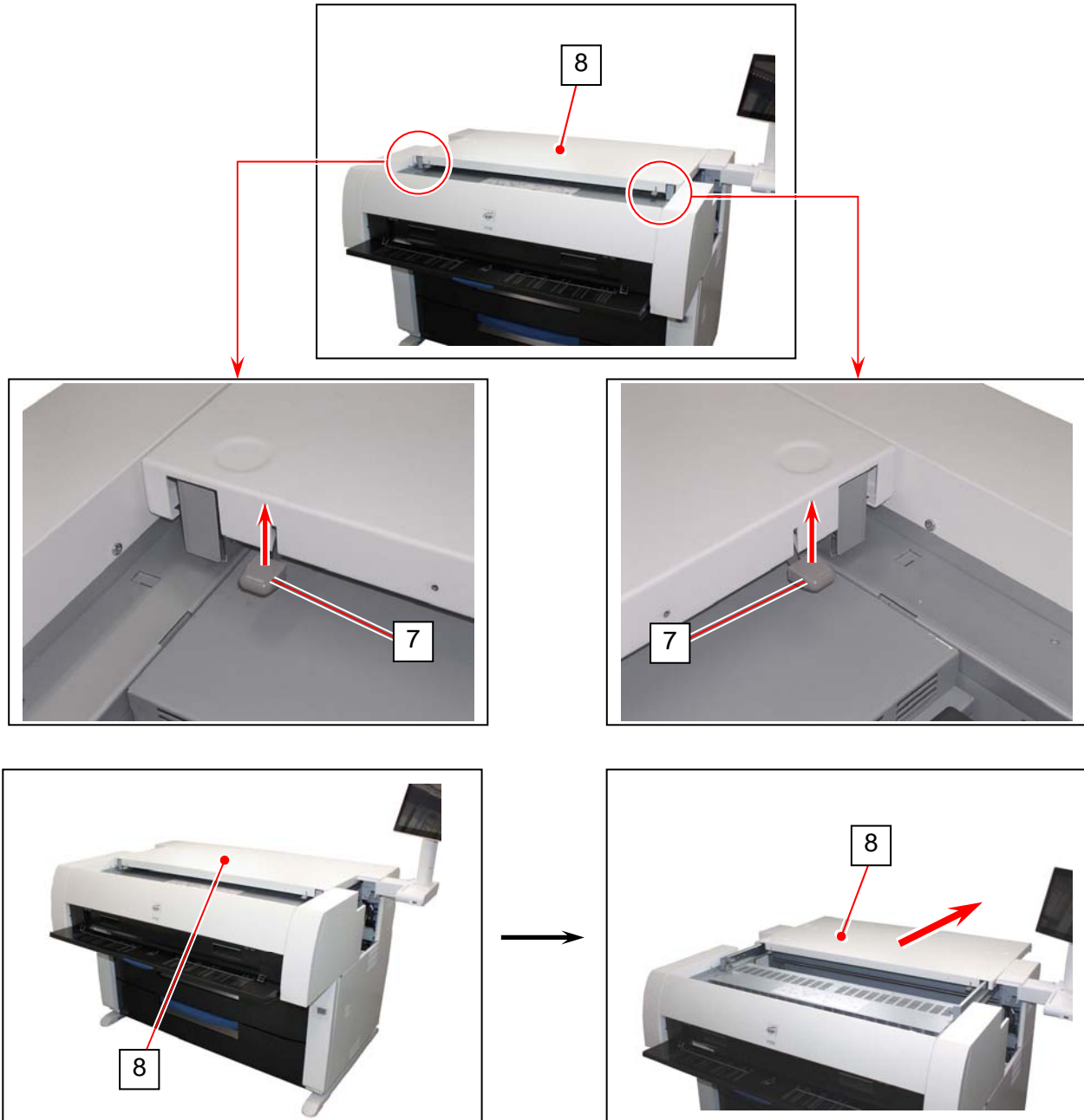

9. Remove the mis-fed paper.

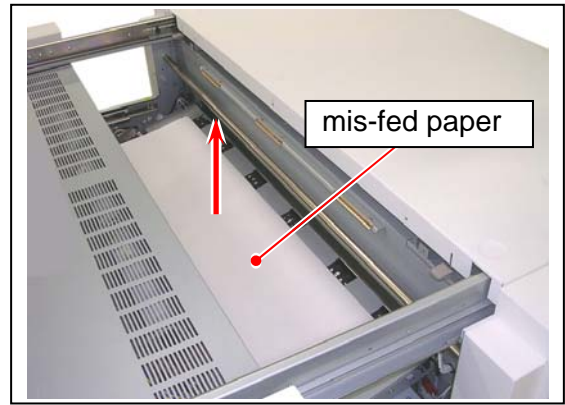

10. Close Top Cover (8).

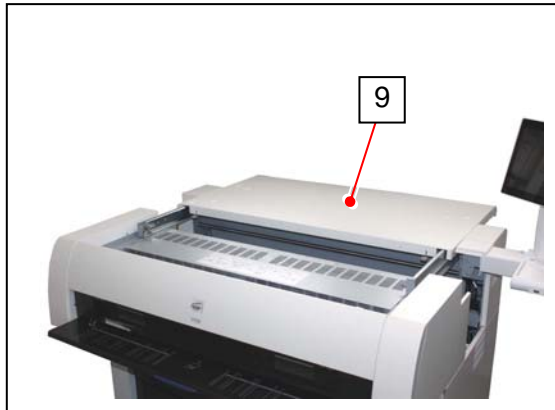

11. Close Upper Frame Unit (5) and Manual Table (4).

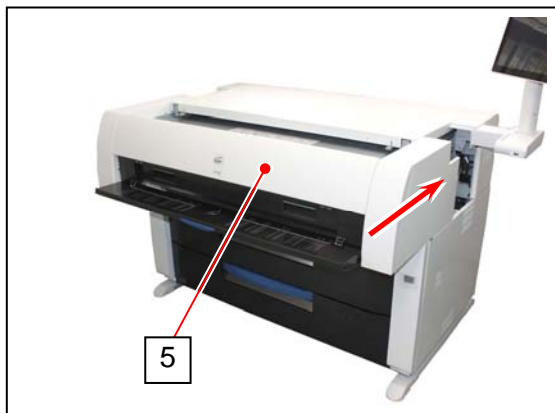

3. 1. 5 Stack Jam

1. Remove print(s) on Print Trays.



2. Pull and remove the mis-fed paper to the top.

If the print cannot be removed, see [3.1.4 Fuser Section Jam] for the later procedure of clearing the jammed print.

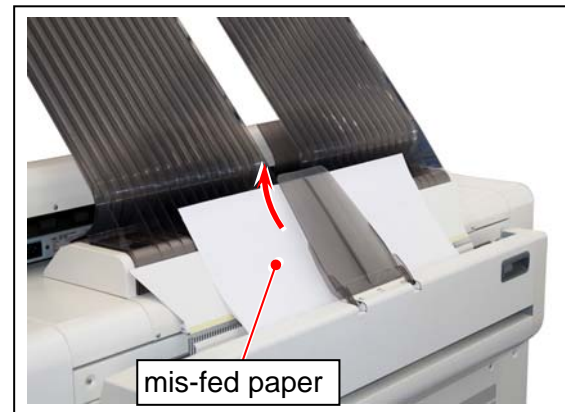

3. 1. 6 Original Jam (for MFP Model)

If an original is mis-fed while scanning, the UI screen shows “Original Jam”. Follow the instruction below to remove the mis-fed original.

1. Lift up both sides (1) of the Scanner Unit

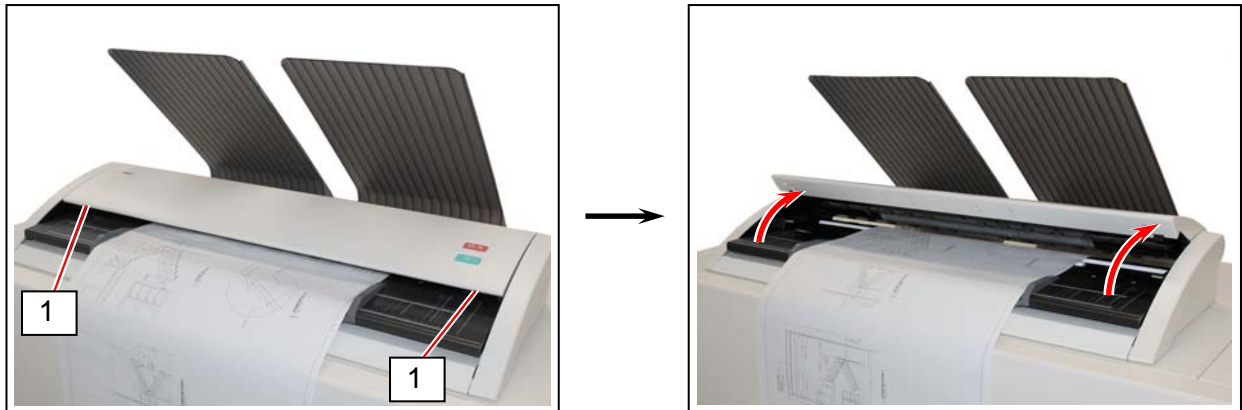

2. Remove a mis-feed original.
3. Gently press the Scanner Unit down and firmly close it.



! NOTE

Press down the Scanner Unit on both sides to close it.
Do not close it by pressing only one side down.

3. 1. 7 Outer Device

The printing paper is mis-fed in the optional device such as Auto Stacker or Folder. Remove the mis-fed paper making reference to the User's Manual of concerning device.

3. 2 Door Open

When any deck/cover is open (not closed firmly), the UI Screen will display “Deck Open” or any other prompt screen.

Close the concerning deck/cover as it is impossible to print, if this error exists.

3. 2. 1 Roll Deck (Deck 1, 2 Open)

“Deck Open” will appear on the UI screen when Upper / Lower Roll Deck is open.

Completely push the concerning Roll Deck toward the printer to firmly close it.

NOTE

The above screen will be indicated if the Roll Deck is not locked correctly, although it may look closed.

Open and close the Roll Deck again, pushing until locked. Ensure both sides of the roll deck are in their correct position.



3. 2. 2 Upper Frame Unit / Top Cover (Front Cover Open)

If either Upper Frame Unit or Top Cover is open, the UI screen shows “Front Cover Open”. Check if the Upper Frame Unit and the Top Cover are closed firmly.

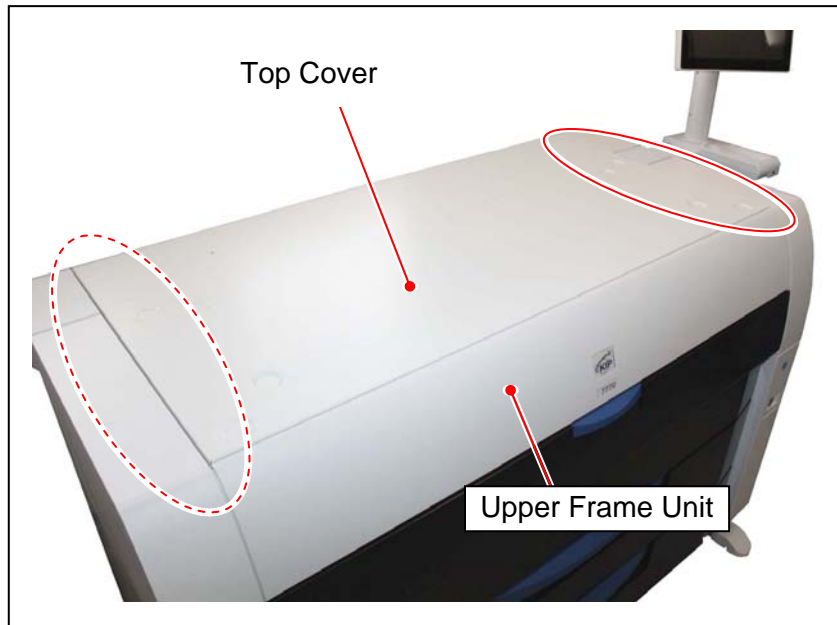

Correct: Both Top Cover / Upper Frame Unit closed firmly

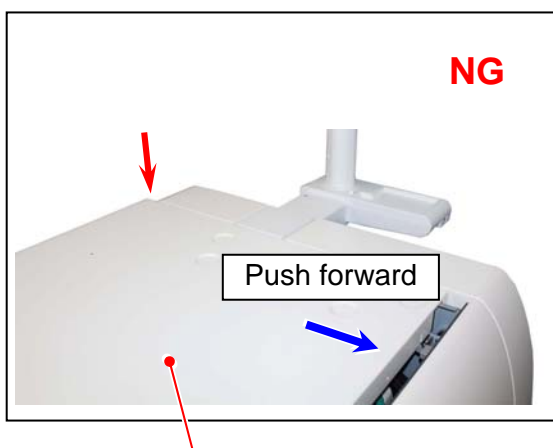

Wrong: Top Cover open

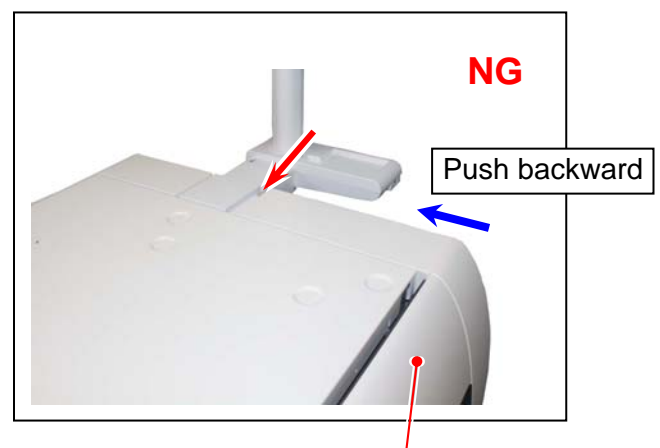

Wrong: Upper Frame Unit open

3. 2. 3 Paper Exit Door (Paper Exit Door Open)

If Paper Exit Door is open, the UI screen shows “Paper Exit Door Open”.
Check if Paper Exit Door is closed firmly.



3. 2. 4 Scanner Unit (Scanner feeder open) (for MFP Model)

The UI screen shows “Scanner feeder open” if the Scanner Unit is open. (not closed properly)

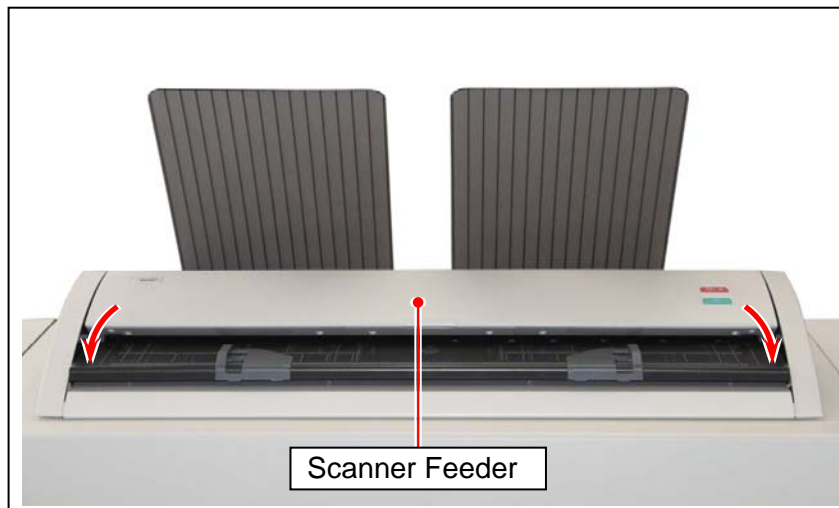

NOTE

Press down the Scanner Unit on both sides to close it.
Do not close it by pressing only one side down.

3.3 Other Operator Call

3.3.1 Roll Replacement

When the printer is running out of a loaded roll media, the UI Screen will display “Out of Paper” sign.

If there is no suitable roll media required for the current print job, the UI Screen will display “Out of Paper” sign as well. Please load the required roll media to any Roll Deck.

For the roll replacement procedure, see [2.3 Replacing the Roll Media].



3.3.2 Toner Empty

When the printer is running out of toner, the UI Screen will display “Toner Empty” sign.

For the toner cartridge replacement procedure, refer to [2.4 Replacing Toner Cartridge].



3. 4 Service Call Errors

If an error with significant effect on the printer occurs, the printer stops the operation and indicates a related Customer Engineer Call Error Code (or description, and its equivalent internal code) on the UI screen.

Call the service staff immediately as these problems can be fixed by a well trained technician only.

Before calling the service staff, try to turn on/off the Printer. If “Service Call Error” is indicated again, turn off the machine, unplug it, and call the service staff with reporting the error description in the UI screen.

Service Call Error

- Fusing Temperature Error
- Motor Error
- Developer Error
- Counter Error
- Cutter Error
- Toner Density Error
- High Voltage Power Supply Error
- Outer Device Error
- Wire Cleaning Error

A corresponding description will be displayed in the top column (status region) in the UI screen.

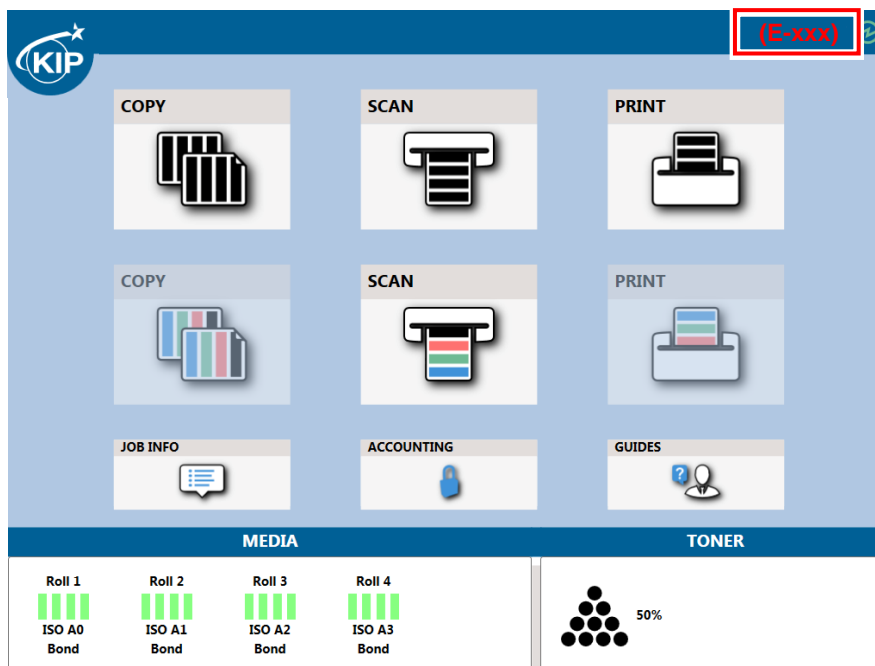

Chapter 4

Maintenance

	Page
4.1 Scanner Unit (for MFP Model)	4-2
4.1.1 Scan Glass, Feed Roller, Guide Plate	4-2
4.1.2 Sensor	4-5
4.2 Touch Screen	4-7

4. 1 Scanner Unit (for MFP Model)

4. 1. 1 Scan Glass, Feed Roller, Guide Plate

It is recommended to clean each Scan Glass, Feeding Rollers and Guide Plates as the scan/copy image may become defective if these parts are dirty.

⚠ NOTE

For ease of visual check, this document shows the Upper Unit fully open (not actual wide).

1. Turn off the Printer.
2. Lift up both sides (1) of the Scanner Unit.



3. Gently wipe the Scan Glass (2) and Feed Rollers (white) (3) with a soft cloth. Equal mixture of water and neutral detergent can be used.

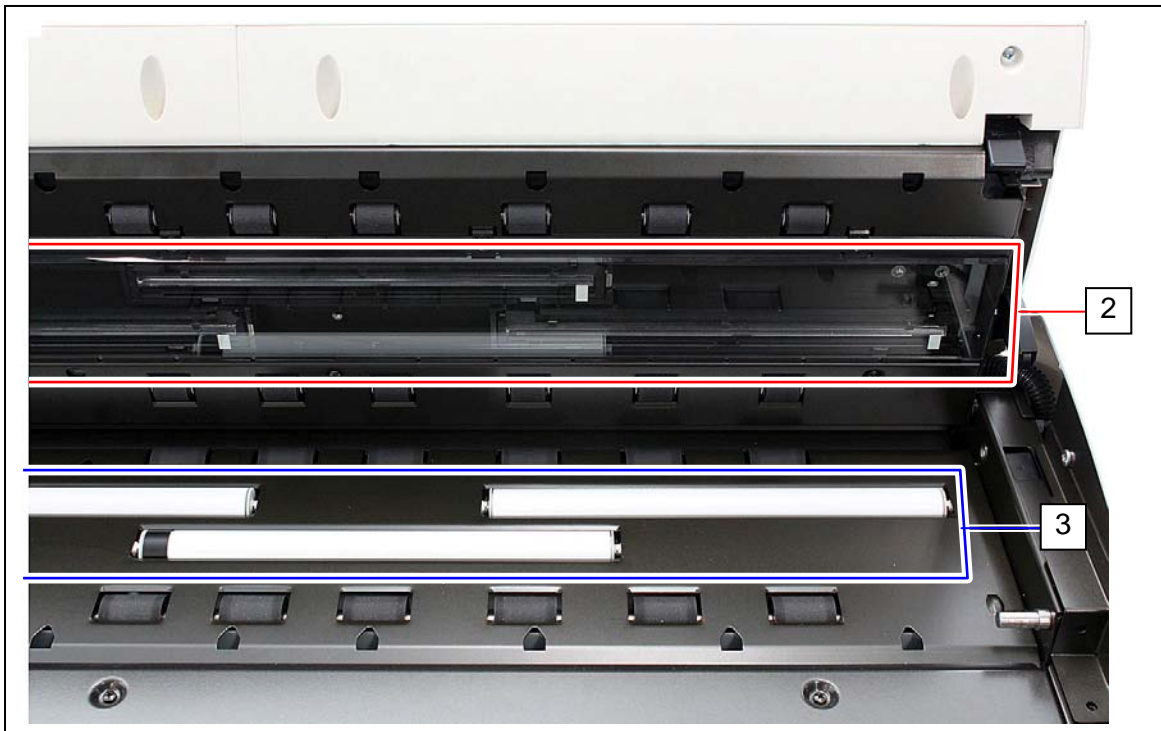

⚠ NOTE

Do not use organic solvent, glass cleaner and anti-static spray for the cleaning.

4. Wipe the Feed Rollers (rubber) (4) with a dry cloth.

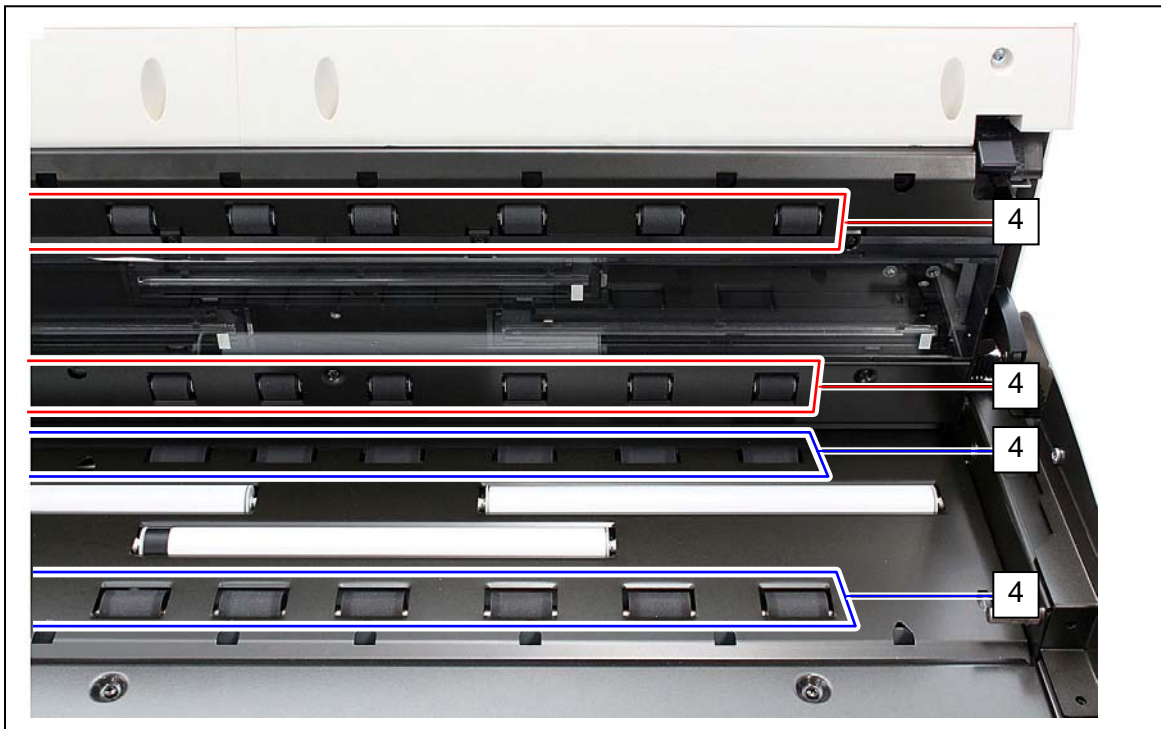

5. Wipe dry the Feeding Rollers.

6. Wipe the Upper Guide Plate (5) and the Lower Guide Plate (6) with a dry cloth.

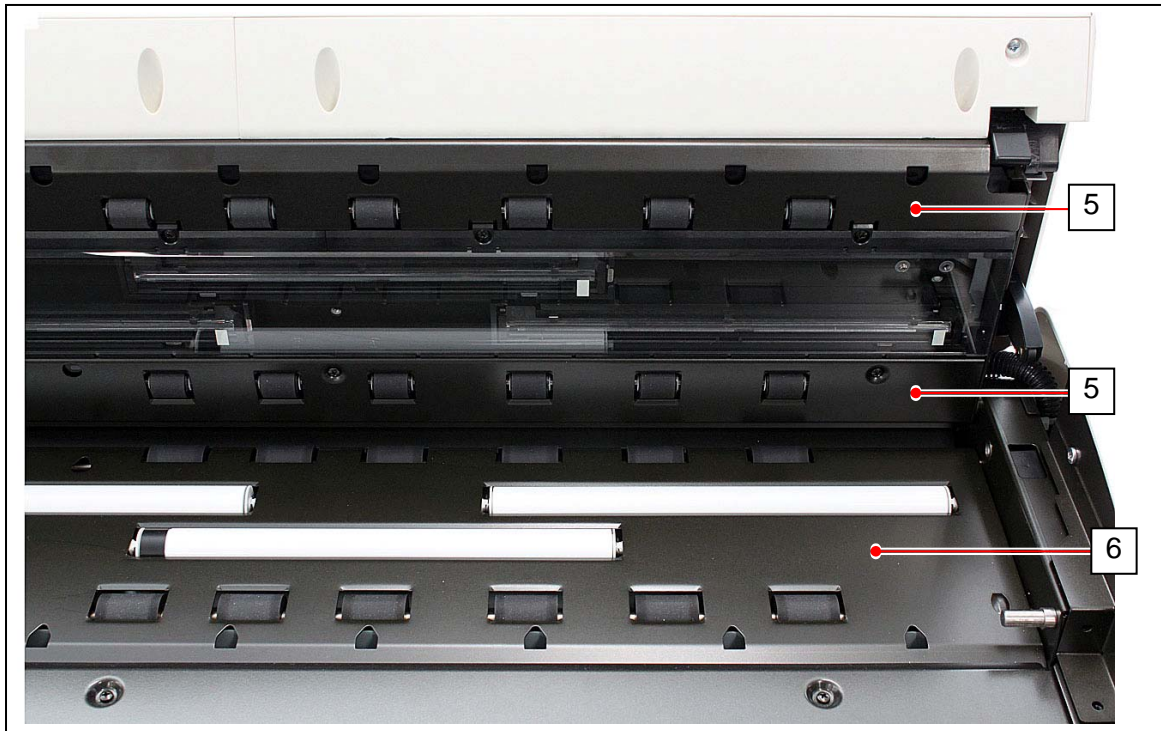

7. Gently press Scanner Unit down and firmly close it.



⚠ NOTE

Press down Scanner Unit on both side to close it.
Do not close it by pressing only one side down.

4. 1. 2 Sensor

If Sensors are dirty, the original may be detected incorrectly.
Perform cleaning or as needed.

! NOTE

For ease of visual check, this document shows the Upper Unit fully open (not actual wide).

1. Turn off the Printer.
2. Lift up both sides (1) of the Scanner Unit.

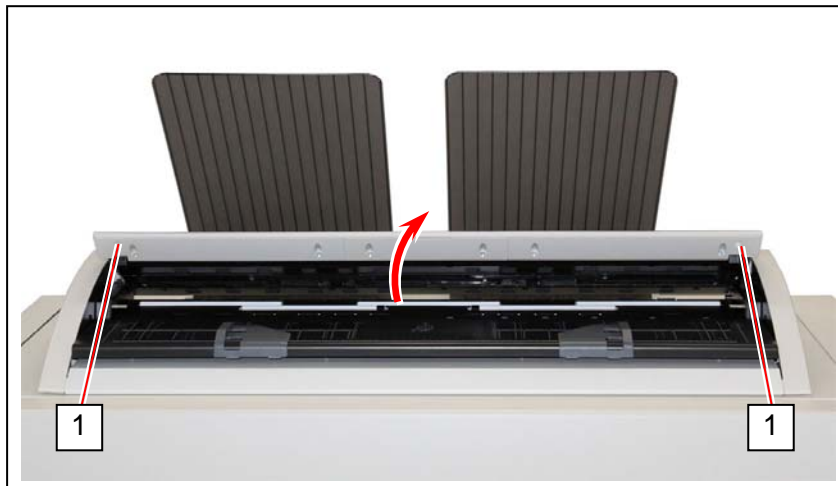

3. Gently wipe Sensors (2) with a dry cotton bud.

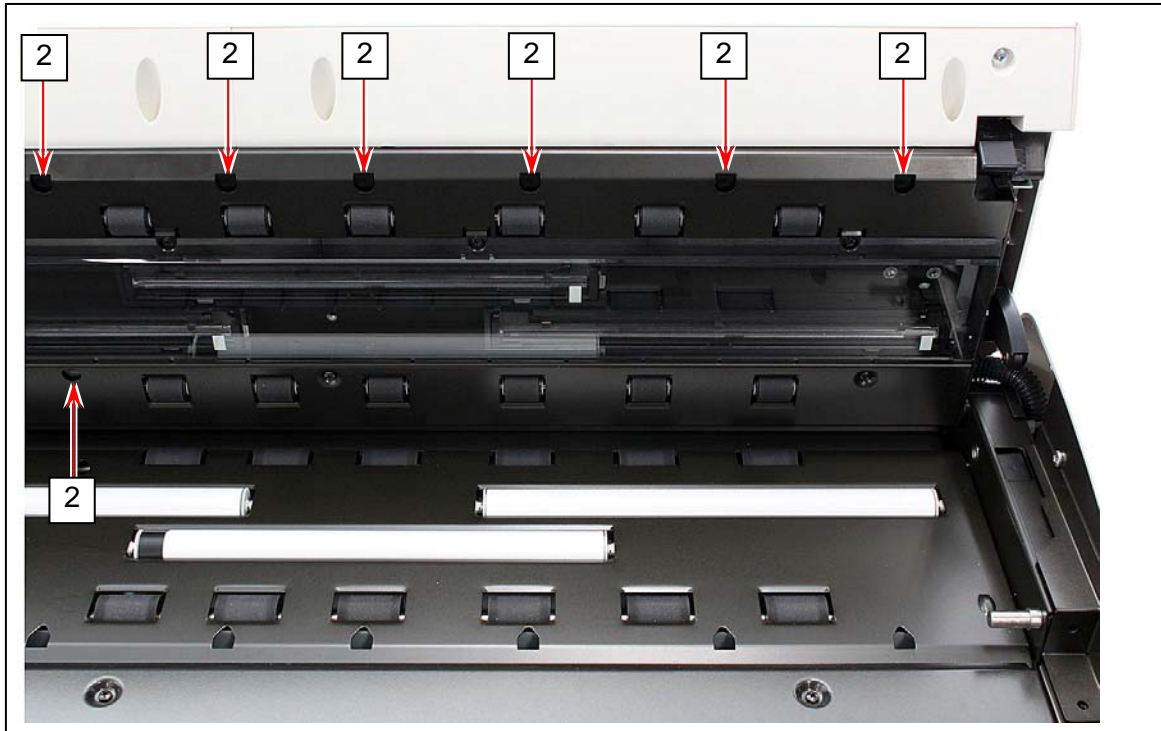

! NOTE

Do not use water, organic solvent, glass cleaner or antistatic spray for cleaning.

4. Gently press Scanner Unit down and firmly close it.

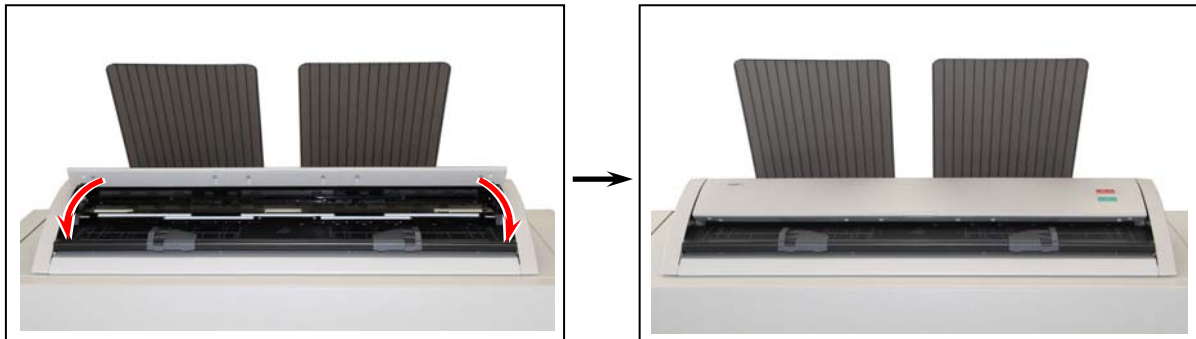

! NOTE

Press down Scanner Unit on both side to close it.
Do not close it by pressing only one side down.

4.2 Touch Screen

1. Wipe the Touch Screen with a dry cloth.



! NOTE

Do not use water, alcohol, organic solvent and glass cleaner for the cleaning.

**WIDE FORMAT PRINTER /
WIDE FORMAT MULTI FUNCTION PRINTER**

KIP 79 Series Hardware Operation Guide

Version A.0 (Issued on May 7, 2016)

**Published by Katsuragawa Electric Co., Ltd.
21-1 Shimomaruko 4-Chome,
Ota-ku, Tokyo 146-8585, Japan**

Please note that some articles, illustrations and photographs might be partially different from the actual machine because of the modification of machine and so on.

© 2016 Katsuragawa Electric Co., Ltd.

No part of this publication may be copied, reproduced or distributed in any form without express written permission from Katsuragawa Electric Co., Ltd.